

Bambu Lab A1 mini

Quick Start

Please review the entire guide before operating the printer.

* Safety Notice: Do not connect to power until assembly is complete.

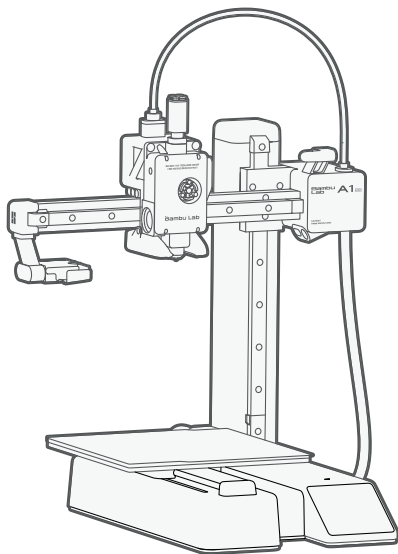

PF002-M



Bambu Studio & Bambu Handy
<https://bambulab.com/download>

What's In The Box

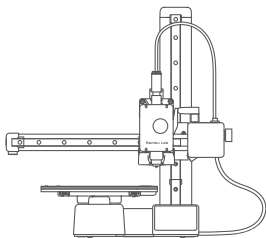

A1 mini



Spool Holder



Accessory Box



Purge Wiper



520mm
PTFE Tube



Sample
Filament



Build Plate



Quick Start

Accessory Box



Unclonging Pin Tool



Allen Key H2



Allen Key H1.5



Bambu
Scraper Blade



Spool Holder Base



Grease & Oil



Cable Organizer



BT2.6-8 Screw (x2)
(For Scraper)



M3-8 Screw (x2)
(For Spool Holder)



M3-12 Screw (x1)
(For Purge Wiper)

Unlock

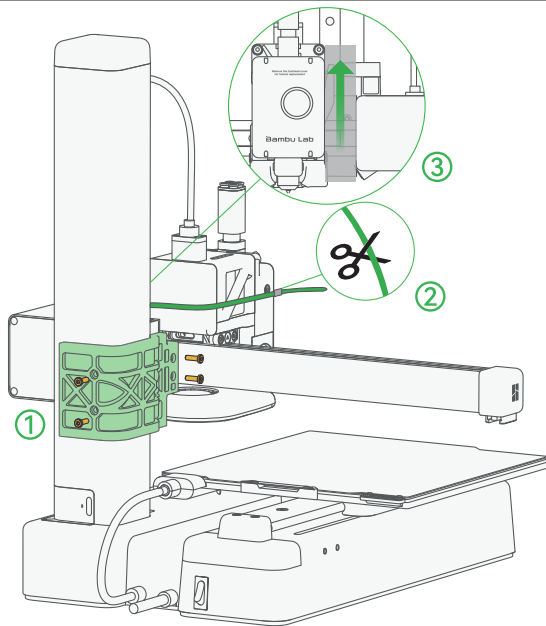

- ① Remove the 4 screws to unlock the Z-axis limiter.
- ② Cut the ziptie wrapped around the toolhead.
- ③ Remove the foam padding.

Lock Heatbed

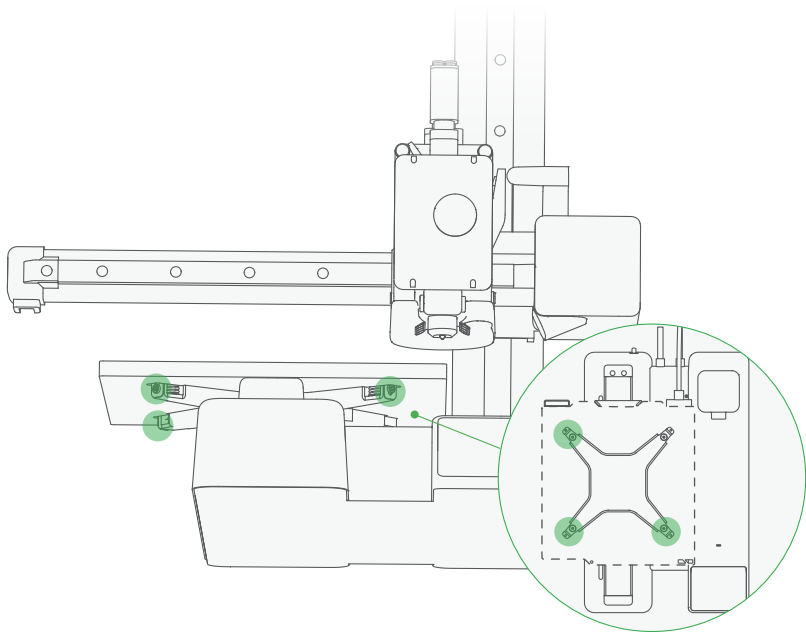

① Tighten the 3 screws circled in green to lock the heatbed.

Purge Wiper Installation

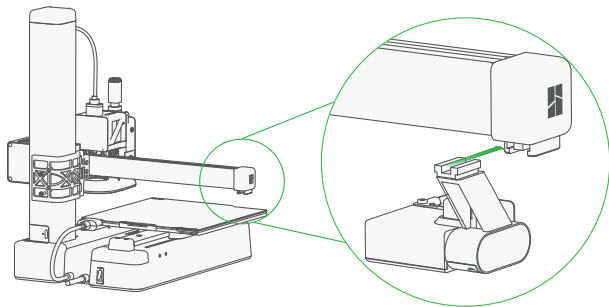

- ① Slide in the Purge Wiper unit into the slot at the end of the X-Axis.

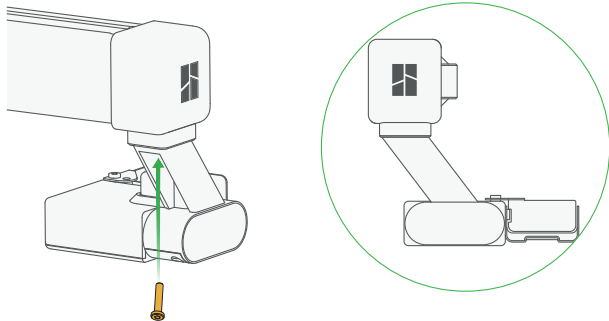

- ② Install the 1*M3-12 screw (For Purge Wiper) from the accessory box to fix the Purge Wiper in place.

Spool Holder Installation

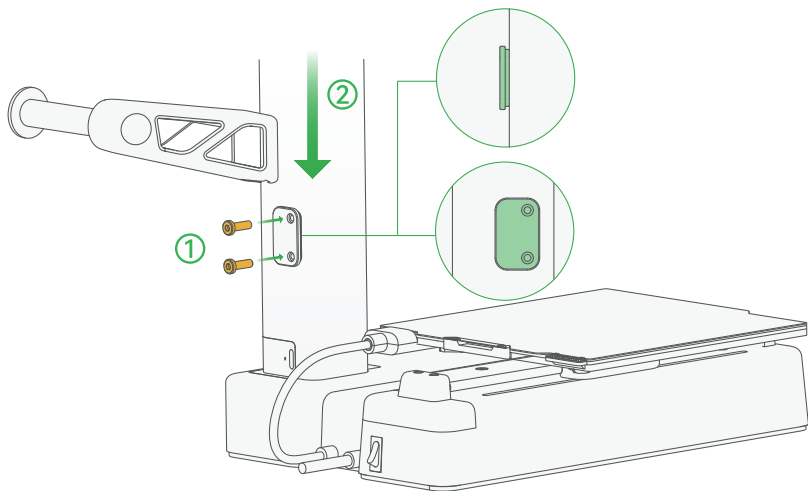

- ① Install the spool holder base plate with the 2*M3-8 screws (For Spool Holder) from the accessory box.
- ② Slide in the spool holder (match the slot orientation).

Powering On

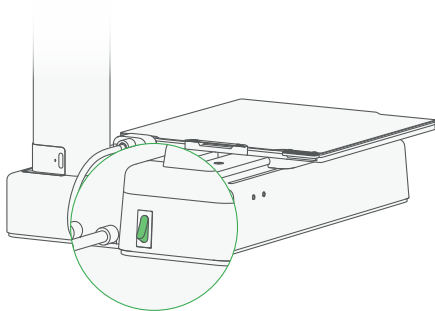

- ① Plug the power cable and turn on the A1 mini using the power switch on the back.

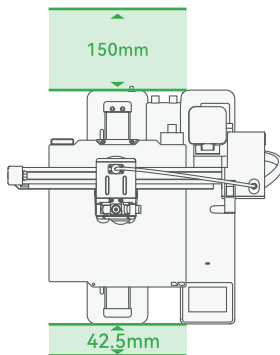

Please leave a safety margin: 150mm at the back and 42.5mm at the front.

Network Setting

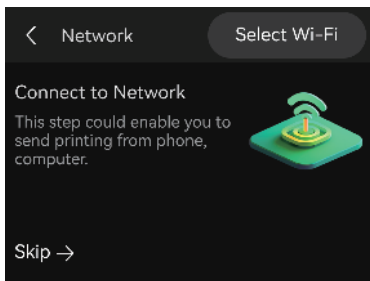

- ① Follow the instructions until you see this screen. Press “Select Wi-Fi” to search for available network.

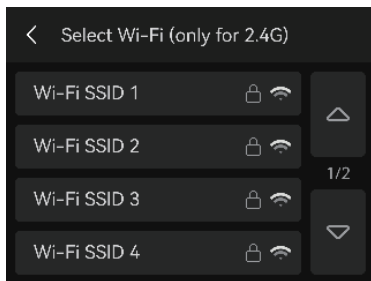

- ② Select your preferred network.

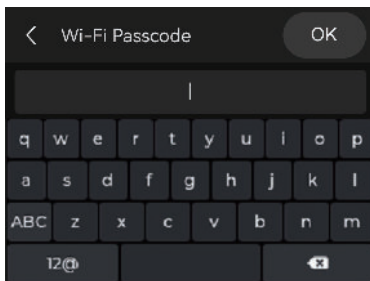

- ③ Input the passcode, and then press “OK”.

Printer Binding

- 1 Download the Bambu Handy App. Register and log in to your Bambu Lab account.
- 2 Use Bambu Handy to scan the QR code on the screen, and bind your printer to your Bambu Lab account.
- 3 Follow the instructions on the screen to complete the initial calibration. It is normal to have vibration and noise during the calibration process.

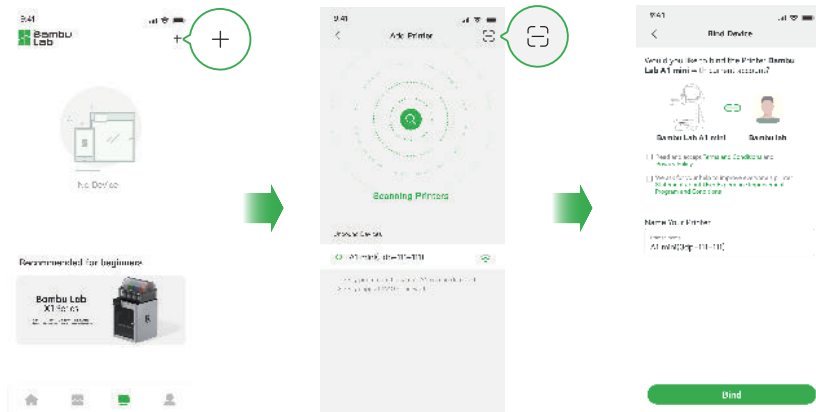
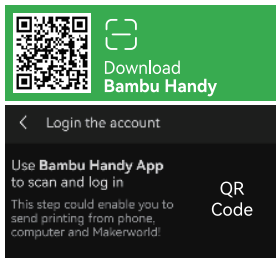

External Spool Loading (for non-AMS use case)

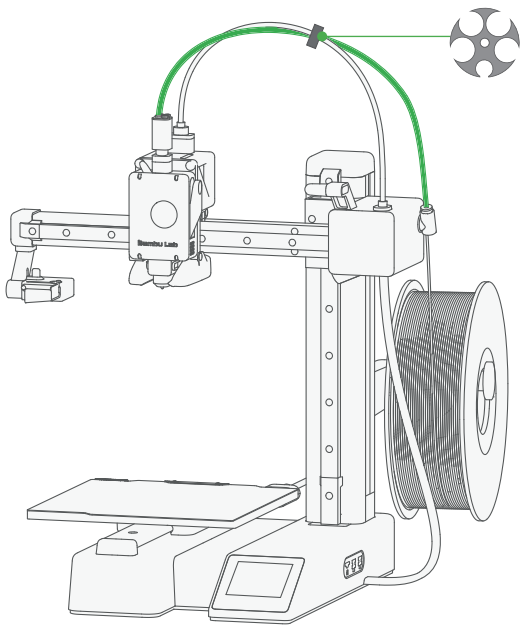

- ① Connect the toolhead filament inlet (either one of four) and the filament guide with the 520mm PTFE tube as shown in the diagram.
- ② Hang filament spool on spool holder then feed the filament line into the PTFE tube as shown in the diagram.

First Print



- ① Press “Print Files” to access the preloaded models on the SD card.



- ② Select the model you want to print.

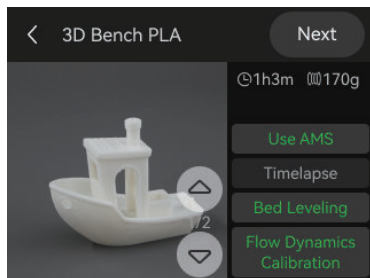

- ③ Turn on “Use AMS” if you are using filaments on AMS.

Turning on “Bed leveling” is recommended.

Turn on “Timelapse” for timelapse video recording.

Specification

Item		Specification
Printing Technology		Fused Deposition Modeling
Body	Build Volume (W×D×H)	180*180*180 mm ³
	Chassis	Steel + Extruded Aluminum
Toolhead	Hot End	All-Metal
	Extruder Gears	Steel
	Nozzle	Stainless Steel
	Max Hot End Temperature	300 °C
	Nozzle Diameter (Included)	0.4 mm
	Nozzle Diameter (Optional)	0.2 mm, 0.6 mm, 0.8 mm
	Filament Cutter	Yes
	Filament Diameter	1.75 mm
Heatbed	Compatible Build Plate	Bambu Textured PEI Plate Bambu Smooth PEI Plate
	Max Build Plate Temperature	80 °C
Speed	Max Speed of Tool Head	500 mm/s
	Max Acceleration of Tool Head	10000 mm/s ²
	Max Hot End Flow	28 mm ³ /s @ABS (Model: 150*150 mm single wall; Material: Bambu ABS; Temperature: 280 °C)
Cooling	Part Cooling Fan	Closed Loop Control
	Hot End Fan	Closed Loop Control
	MC Board Cooling Fan	Closed Loop Control
Supported Filament	PLA, PETG, TPU, PVA	Ideal
	ABS, ASA, PC, PA, PET, Carbon/Glass Fiber Reinforced Polymer	Not Recommended
Sensors	Monitoring Camera	Low Rate Camera (up to 1080P) Timelapse Supported
	Filament Run Out Sensor	Yes
	Filament Odometry	Yes
	Power Loss Recover	Yes
	Filament Tangle Sensor	Yes
Physical Dimensions	Dimensions (W×D×H)	347*315*365 mm ³
	Net Weight	5.5 kg

Specification

Electrical Parameters	Input Voltage	100-240 VAC, 50/60 Hz
	Max Power	150 W
Electronics	Display	2.4 inches 320*240 IPS Touch Screen
	Connectivity	Wi-Fi, Bambu-Bus
	Storage	Micro SD Card
	Control Interface	Touch Screen, APP, PC Application
	Motion Controller	Dual-Core Cortex M4
Software	Slicer	Bambu Studio Support third party slicers which export standard Gcode such as SuperSlicer, PrusaSlicer and Cura, but certain advanced features may not be supported.
	Slicer Supported OS	MacOS, Windows
Wi-Fi	Frequency Range	2412 MHz - 2472 MHz (CE) 2412 MHz - 2462 MHz (FCC) 2400 MHz - 2483.5 MHz (SRRC)
	Transmitter Power (EIRP)	≤ 21.5 dBm (FCC) ≤ 20 dBm (CE/SRRC)
	Protocol	IEEE 802.11 b/g/n



Bambu Studio
Bambu Handy

<https://bambulab.com/download>



Bambu Lab

Enjoy!

www.bambulab.com