



# Ra-01H Specification

Version V1  
copyright ©2019

## Disclaimer and copyright notice

The information in this article, including the URL address for reference, is subject to change without prior notice. The Documentation is provided "as is" without any warranty, including any warranties of merchantability, fitness for a particular purpose, or non-infringement, and any warranties mentioned in the proposal, specification or sample. This document is not responsible for any infringement of any patent rights arising out of the use of the information in this document. No license, express or implied, by estoppel or otherwise, is hereby granted.

The test data obtained in this paper are all obtained by Ai-Thinker laboratory, and the actual results may be slightly different. The Wi-Fi alliance membership mark is owned by the WiFi alliance.

All trade mark names, trademarks and registered trademarks mentioned herein are the property of their respective owners and are hereby declared.

The final interpretation right is owned by Shenzhen Ai-Thinker Technology Co., Ltd.

### Note

The contents of this manual may be changed due to the version upgrade of the product or other reasons. Shenzhen Ai-Thinker Technology Co., Ltd. reserves the right to modify the contents of this manual without any notice. This manual is only used as a guide, and Shenzhen Ai-Thinker Technology Co., Ltd. makes every effort to provide accurate information in this manual, but Shenzhen Ai-Thinker Technology Co., Ltd. does not ensure that the contents of the manual are completely true, all statements in this manual, All statements and information in this manual. and the recommendations do not constitute for any warranty, express or implied.



## Contents

1. Product Overview.....	5
2. Electrical parameters.....	7
3. Appearance size.....	9
4. Pin definition.....	9
5. Schematics.....	11
6. Design Guidance.....	11
7. Package Information.....	14
8. Contacts.....	14

## 1. Product Overview

Ai-Thinker lora Series Module (Ra-01H) designed and developed by Ai-Thinker .This module is used for long distance spread spectrum communication., Its RF chip SX1276 (as show as figure 1) Mainly used LoRa™ remote modem , for ultra-long-distance spread spectrum communication , strong anti-interference , can minimize current consumption. With the help of the SEMTECH the patent technology of LoRa™, SX1276 with -148dBm high sensitive , long range transmission, high reliability. Meantime , relative traditional modulation technique , LoRa™ modulation technique has obvious advantages in anti-blocking and selection, It solves the problem that traditional design scheme can not consider distance, anti-interference and power consumption simultaneously.

Its application can be automatic meter reading, home building automation, security system, remote irrigation system.

### Features

- LoRa™ modem .
- Support 903/927MHz
- Operating voltage is 3.3V, the maximum output current is105mA.
- Low power Consumption in a received stat,the received current is12.5mA, stand-by current is 1.6mA
- High sensitivity: as low as-140dBm
- Small volume double row stamp hole patch package
- SPI interface, using half duplex communication, with CRC、up to 256-byte packet engine

## Main parameters

### Charter 1.1 main parameters instruction

<b>Module name</b>	Ra-01H
<b>Package</b>	SMD-16
<b>Size</b>	17*16*3.2(±0.2)MM
<b>Antenna</b>	Spring Antenna
<b>Spectrum range</b>	903~927MHz
<b>Working temperature</b>	-20 °C ~ 70 °C
<b>Storage environment</b>	-40 °C ~ 125 °C , < 90%RH
<b>Power supply</b>	2.7~3.6V, typical value 3.3V, current over 200mA
<b>Support Interface</b>	SPI
<b>Programmable bit rate</b>	300kbps
<b>Certification</b>	REACH、RoHS

## 2. Electrical parameters

### Electrical character

Parameter	Symbol	Min	Typ	Max	Unit
Operating Temperature	TOPR	-20	25	70	°C
Supply Votage	VDD	2.7	3.3	3.6	V

### Digital port characteristics

Description		Typ		Unit	
Operating Cooperation		903~927		MHz	
IO	Name	Min	Typ	Max	Unit
IO level	VIO	2.7	3.3	3.6	V
Low input logic level	VIL	-	-	0.2	V
High input logic level	VIH	0.8	-	-	V
Low output logic level	VOL	-	-	0.1	V
High output logic level	VOH	0.9	-	-	V

### • SPI Interface features

Name	Description	Condition	Min	Typ	Max	Unit
Fsck	SCK frequency	-	-	-	10	MHz
tch	SCK High level time	-	50	-	-	ns
tcl	SCK Low level time	-	50	-	-	ns

trise	SCK Rise time	-	-	5	-	ns
tfall	SCK Fall time	-	-	5	-	ns
tsetup	MOSI Time setting	Change from MOSI to the rising edge of SCK	30	-	-	ns
thold	MOSI Duration	From the rising edge of SCK to the change of MOSI	20	-	-	ns
tnsetup	NSS Set up time	From the falling edge of NSS to the rising edge of SCL	30	-	-	ns
tnhold	NSS Time maintain	From the falling edge of SCL to the rising edge of NSS,normal mode	100	-	-	ns
tnhigh	Spi Access interval NSS High level time	-	20	-	-	ns
T_DATA	DATA maintenance and set up time	-	250	-	-	ns

### 3. Appearance size

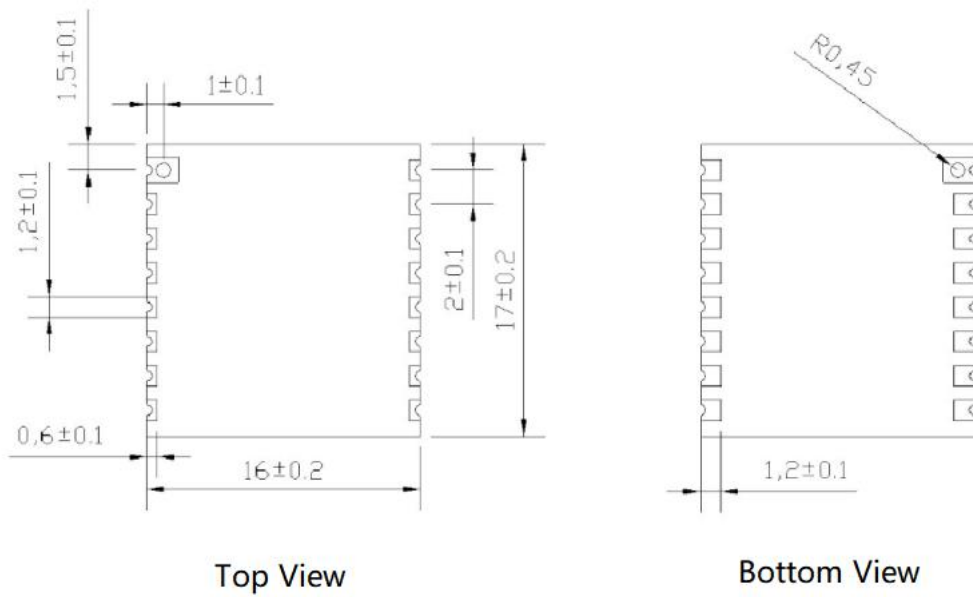

### 4. Pin definition

Ra-01H module with 16 interface, show as figure 2.1, table 2.2 is the interface definition.

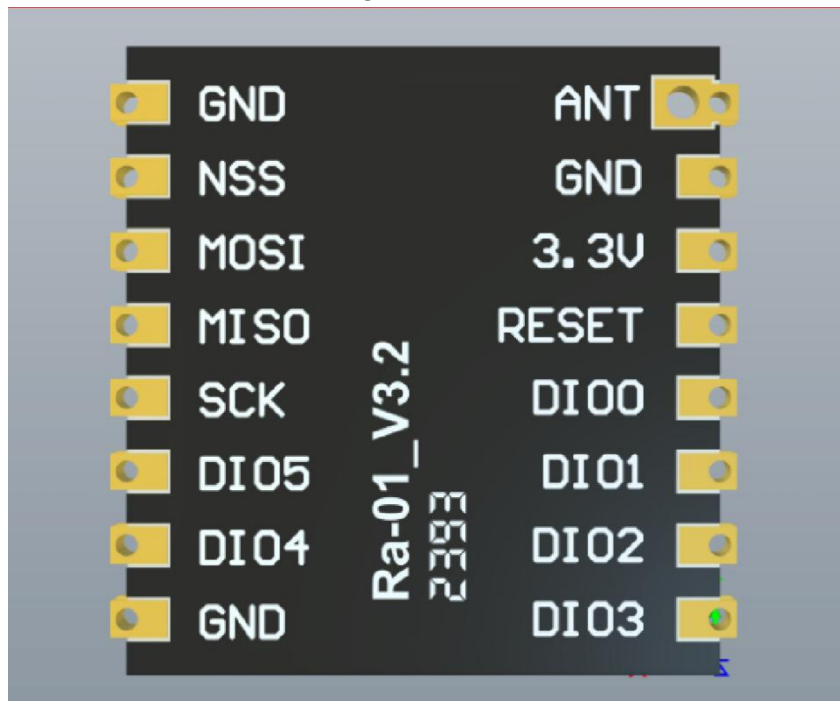

Ra-01H Figure 2.1 Ra-01HPin diagram

Table 2.2 Pin function definition

No.	Name	Function instruction
1	ANT	Antenna
2	GND	Ground
3	3.3V	3.3V power supply (VDD)
4	RESET	Reset
5	DIO0	Digital I00 software configuration
6	DIO1	Digital I01 software configuration
7	DIO2	Digital I02 software configuration
8	DIO3	Digital I03 software configuration
9	GND	ground
10	DIO4	Digital I04 software configuration
11	DIO5	Digital I05 software configuration
12	SCK	SPI clock input
13	MISO	SPI data output
14	MOSI	SPI data input
15	NSS	SPI Selection input
16	GND	ground

The six general IO pin of SX1276 can be available in LoRa™ mode.

Their mapping depends on the configuration of the two registers RegDioMapping1 and RegDioMapping2.

Operating Mode	DIOx Mapping	DIO5	DIO4	DIO3	DIO2	DIO1	DIO0
All	00	ModeReady	CadDetected	CadDone	Fhss Change Channel	RxRimeout	RxDone
	01	ClkOut	PIILock	Valid Header	Fhss Change Channel	Fhss Change Channel	TxDone
	10	ClkOut	PIILock	PayloadCrc Error	Fhss Change Channel	CadDetected	CadDoe
	11	-	-	-	-	-	-

## 5. Schematics

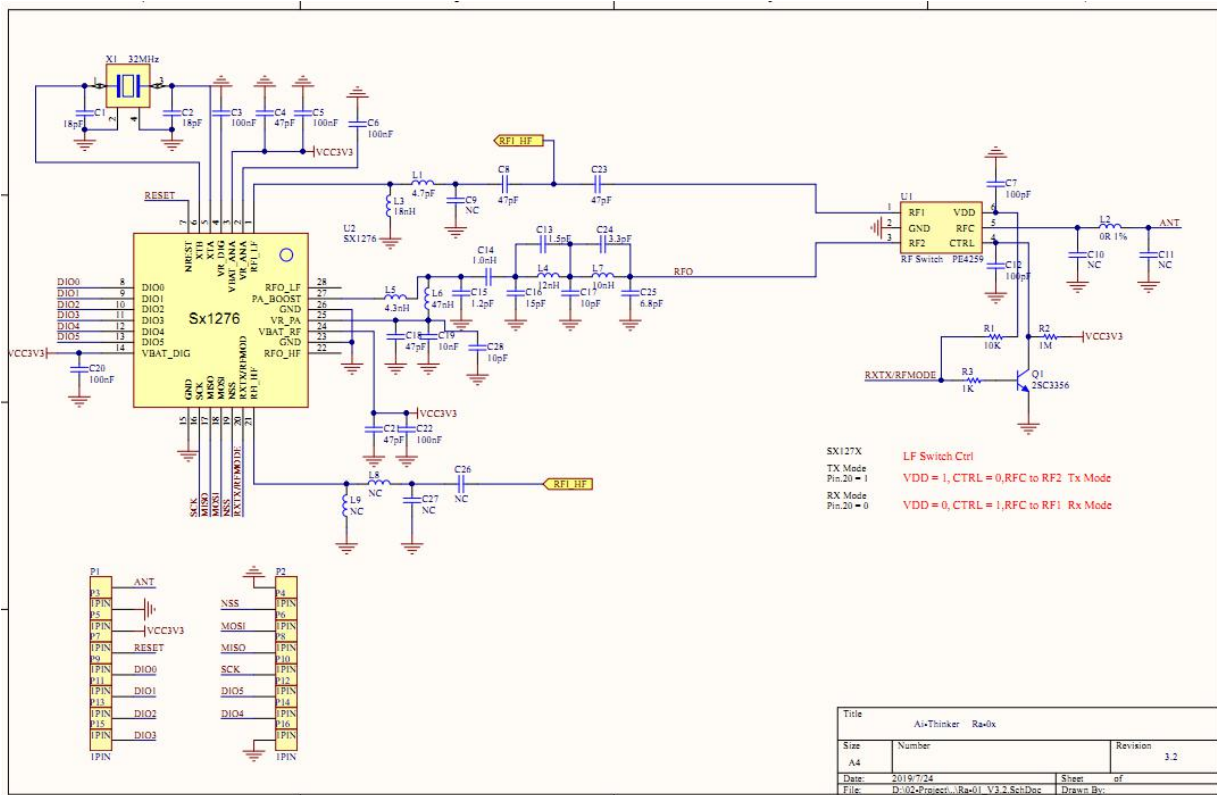

## 6. Design Guidance

### 1、Application Circuit

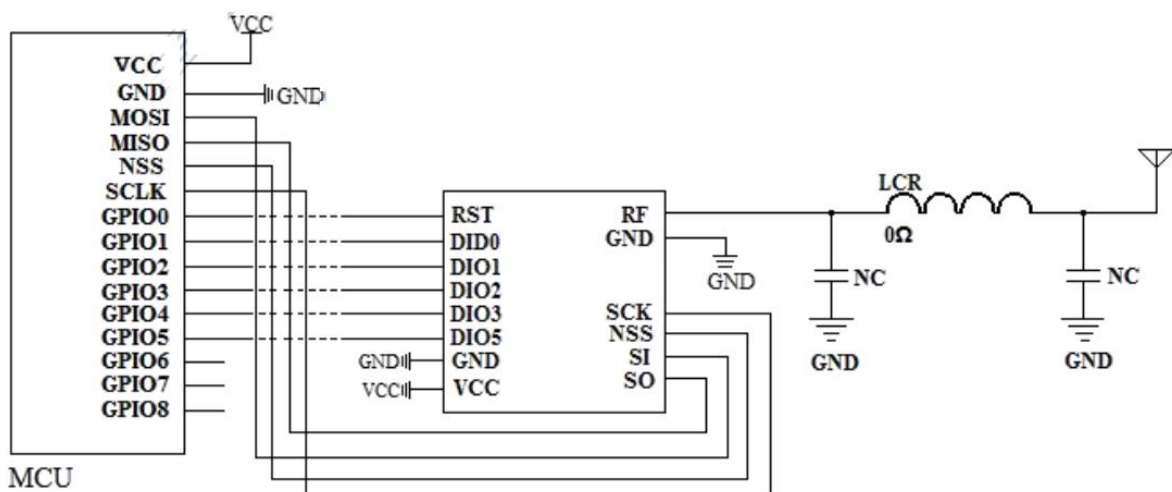

### 2、Antenna Install

(1)、Ra-01H require to weld antenna, the module is compatible with the half-hole

pad and the round-hole pad.

(2)、In order to meet the performance of the on-board antenna, metal parts are prohibited from being placed around the antenna.

### 3、Power Supply

(1)、Recommended voltage 3.3 V, Peak:Current over 200mA .

(2)、It is recommended to use the LDO power supply; If DC-DC is used, the ripple is controlled within 30 mV.

(3)、DC-DC power supply circuit is recommended to reserve the position of the dynamic response capacitor, and the output ripple can be optimized when the load change is large.

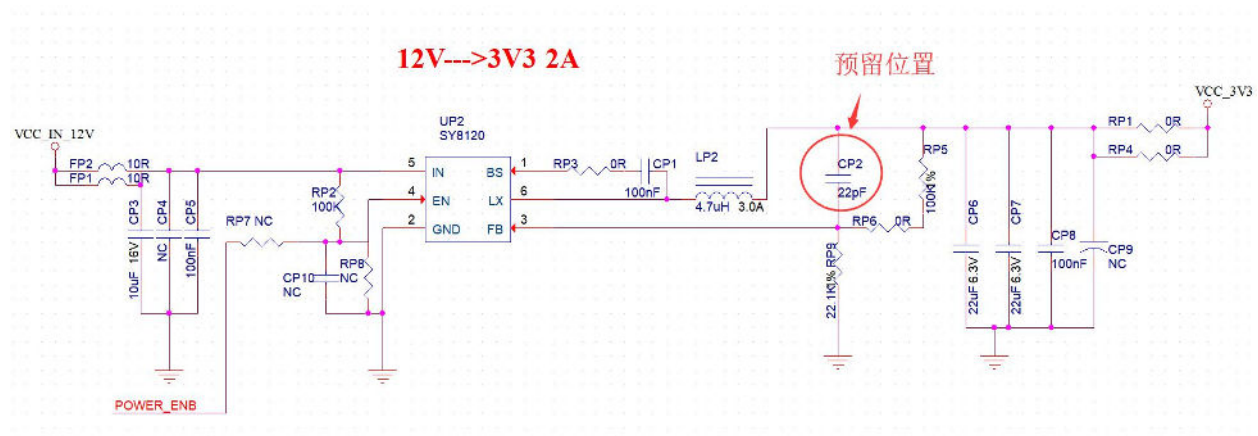

### 4、GPIO

- (1) .There's a few GPIO port design outside the module, if require to use  
recommand the IO port to tadem the resistance for 10 to 100 ohmic.This can suppress overshoot, It's even more stable on both sides.It would help both EMI and ESD.
- (2) .Special IO's pull up and down, should refer to the direction of use  
in Specification, here will affect the startup configuration of the module.
- (3) .IO port of module is 3.3V,if master control and the IO level of module  
doesn't match,required to add Level swithing circuit.
- (4) .If IO port connected to out-ring interface directly, pin or other etc, recommended to reserved ESD  
device near the terminal of IO circuit line .

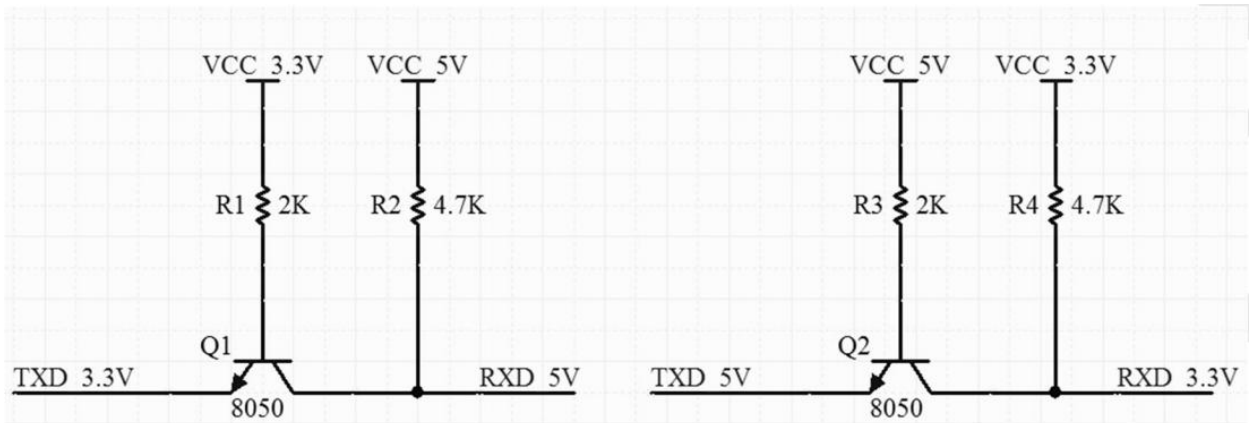

Level switching circuit

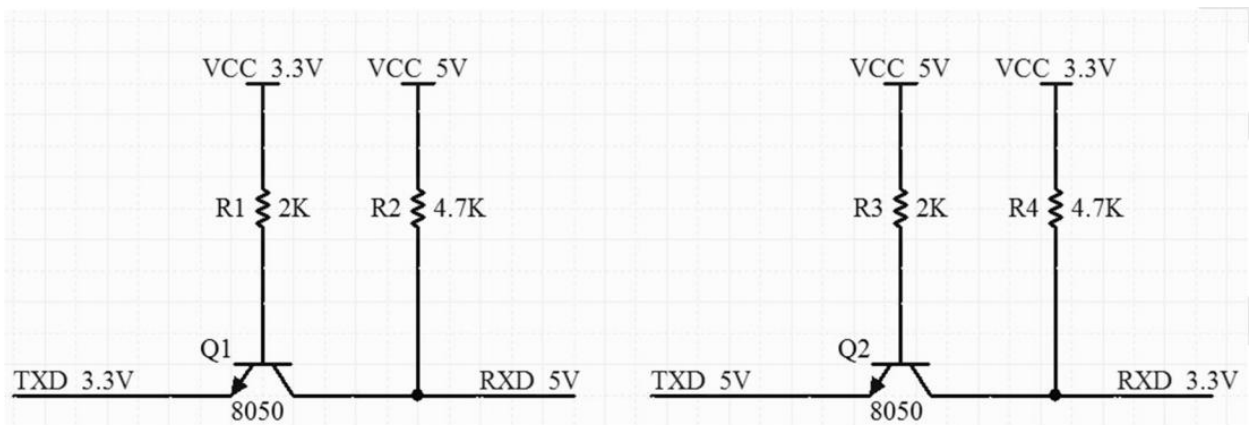

## 7. Package Information

As shown below, the packing of Ra-01H is a tape.



## 8. Contacts

Company website: <https://www.ai-thinker.com>

Developer Wiki: <http://wiki.ai-thinker.com>

Company forum: <http://bbs.ai-thinker.com>

Sampling purchasing: <https://anxinke.taobao.com>

Business cooperation: [sales@aithinker.com](mailto:sales@aithinker.com)

Technology support: [support@aithinker.com](mailto:support@aithinker.com)



## **Integration instructions for host product manufacturers according to KDB 996369 D03 OEM Manual v01**

### **2.2 List of applicable FCC rules**

The Ra-01H is an LoRa Module with digitally modulated systems using an LoRa/FSK/OOK modulation. It operates on the 903MHz~927MHz band and, therefore, is within U.S. FCC part 15.247 standard

### **2.3 Specific operational use conditions**

The EUT is a LoRa Module

Operation Frequency: 903MHz~927MHz

Modulation Type: LoRa/FSK/OOK

Number Of Channel: 25CH

Antenna Designation: Spring Antenna

Antenna Gain: 3dBi

Ai-Thinker lora Series Module (Ra-01H) designed and developed by Ai-Thinker .This module is used for long distance spread spectrum communication., Its RF chip SX1276 (as show as figure 1) Mainly used LoRaTM remote modem , for ultra-long-distance spread spectrum communication , strong anti-interference , can minimize current consumption. With the help of the SEMTECH the patent technology of LoRaTM, SX1276 with -148dBm high sensitive , long range transmission, high reliability. Meantime , relative traditional modulation technique , LoRaTM modulation technique has obvious advantages in anti-blocking and selection, It solves the problem that traditional design scheme can not consider distance, anti-interference and power consumption simultaneously. Its application can be automatic meter reading, home building automation, security system, remote irrigation system.

### **2.4 Limited module procedures**

not applicable; Single Modular Approval Request

### **2.5 Trace antenna designs**

Not applicable;

### **2.6 RF exposure considerations**

To maintain compliance with FCC's RF Exposure guidelines, This equipment should be installed and operated with minimum distance between 20cm the radiator your body: Use only the supplied antenna.

### **2.7 Antennas**

The Ra-01H is an LoRa Module beams signals and communicates with its antenna, which is Spring Antenna. The Spring Antenna gain is 3dBi. Antenna could not be in no-load state when module is working. During debugging, it is suggested to add 50 ohms load to the antenna port to avoid damage or performance degradation of the module under long-time no-load condition.

### **2.8 Label and compliance information**

The final end product must be label in a visible area with the following

Host must Contains FCC ID: 2ATPO-RA-01H. If the size of the end product is larger than 8x10cm, then the following FCC part 15.19 statement has to also be available on the label: This device complies with Part 15 of FCC rules. Operation is subject to the following two conditions:

(1) this device may not cause harmful interference and

(2) this device must accept any interference received, including interference that may cause undesired operation.

### **2.9 Information on test modes and additional testing requirements**

Data transfer module demo board can control the EUT work in RF test mode at specified test channel.

### **2.10 Additional testing, Part 15 Subpart B disclaimer**

The module without unintentional-radiator digital circuit, so the module does not required an evaluation by FCC Part 15 Subpart B. The host should be evaluated by the FCC Subpart B.

## ATTENTION

This device is intended only for OEM integrators under the following conditions:

- 1) The antenna must be installed such that 20 cm is maintained between the antenna and users, and
- 2) This device and its antenna(s) must not be co - located with any other transmitters except in accordance with FCC multi - transmitter product procedures. Referring to the multi - transmitter policy, multiple transmitter(s) and module(s) can be operated simultaneously without C2P.
- 3) For all products market in US, OEM has to limit the Operating Frequency: 903MHz~927MHz by supplied firmware programming tool. OEM shall not supply any tool or info to the end - user regarding to Regulatory Domain change.

## USERS MANUAL OF THE END PRODUCT:

In the user manual of the end product, the end user has to be informed to keep at least 20cm separation with the antenna while this end product is installed and operated. The end user has to be informed that the FCC radio - frequency exposure guidelines for an uncontrolled environment can be satisfied. The end user has to also be informed that any changes or modifications not expressly approved by the manufacturer could void the user's authority to operate this equipment.

If the size of the end product is smaller than 8x10cm, then additional FCC part 15.19 statement is required to be available in the users manual: This device complies with Part 15 of FCC rules.

Operation is subject to the following two conditions:

- (1) this device may not cause harmful interference and
- (2) this device must accept any interference received, including interference that may cause undesired operation.

## FCC WARNING

This device complies with part 15 of the FCC Rules. Operation is subject to the following two conditions:

Any changes or modifications not expressly approved by the party responsible for compliance could void the user's authority to operate the equipment.

NOTE: This equipment has been tested and found to comply with the limits for a Class B digital device, pursuant to Part 15 of the FCC Rules. These limits are designed to provide reasonable protection against harmful interference in a residential installation. This equipment generate, uses and can radiate radio frequency energy and, if not installed and used in accordance with the instructions, may cause harmful interference to radio communications. However, there is no guarantee that interference will not occur in a particular installation.

If this equipment does cause harmful interference to radio or television reception, which can be determined by turning the equipment off and on, the user is encouraged to try to correct the interference by one or more of the following measures:

- Reorient or relocate the receiving antenna.
- Increase the separation between the equipment and receiver.
- Connect the equipment into an outlet on a circuit different from that to which the receiver is connected.
- Consult the dealer or an experienced radio/TV technician for help.