

ITEM:YF-S403

YP-S403



Product Features:

1. The appearance of this product is light and flexible, small size, easy to install.
2. Impeller with stainless steel beads inside, always wear.
3. Seal using the upper and lower force structure will never leak.
4. Hall elements imported from Germany, and encapsulated with potting, To prevent water, never aging.
5. All raw materials are in line with ROHS testing standards

Product Description:
Water flow sensor is mainly composed of plastic body, water rotor components and Hall sensors. It is installed in the water heater inlet, used to detect water flow, when the water flow through the rotor assembly, The magnetic rotor rotates and the rotational speed changes with the flow rate change, the Hall sensor outputs the corresponding pulse

Signal, feedback to the controller, the controller to determine the size of water flow, regulation.

A. Introduction:

Water flow sensor consists of a plastic body, the flow of the rotor assembly and a Hall sensor.

It is installed in the water heater inlet end for detecting the flow of water when the water flow through the rotor assembly,

A magnetic rotor and the flow speed is adapted to change, the Hall sensor output corresponding pulse

Signal feedback to the controller, the controller is determined by the size of the water traffic regulation.

B. A schematic view of the mounting direction

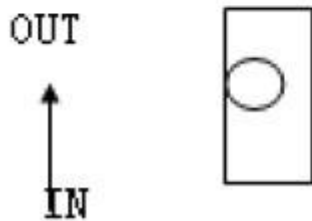

C. Output waveforms:

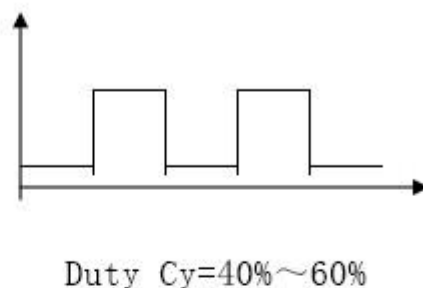

D. Wiring:

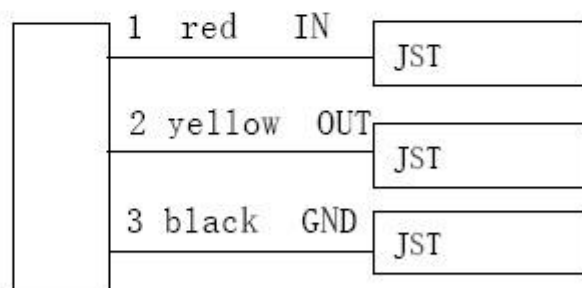

E. Technical Parameters:

Scope: Suitable for automatic gas water heater

Technical Parameters

- 1, the minimum rated operating voltage DC 5V-24V
- 2, the maximum operating current of 15 mA (DC 5V)
- 3, the working voltage range DC 5 ~ 18V
- 4, the load capacity of ≤ 10 mA (DC 5V)
- 5, the use of temperature range ≤ 80 °C
- 6, the use of humidity range of 35% to 90% RH (no frost state)
- 7, to allow pressure water pressure below 1.75Mpa
- 8, save the temperature -25 ~ +80 °C
- 9, save humidity 25% ~ 95% RH
- 1, the output pulse high > DC 4.5 V (input voltage DC 5 V)
- 2, the output pulse low <DC 0.5 V (input voltage DC 5 V)
- 3, precision
(Flow rate - pulse output) 1 to 25 L / min $\pm 3\%$
- 4, the output pulse duty cycle $50 \pm 10\%$
- 5, the output rise time 0.04μ S
- 6, the output fall time 0.18μ S
- 7, the flow - pulse characteristics of the level of test pulse frequency (Hz) = [5.0Q] $\pm 3\%$ (level test) (Q for the flow L / min)
- 8, impact-resistant packaging products, from 50cm height X, Y, Z direction free fall to the concrete surface without exception, Accuracy changes within 5%.
- 9, insulation resistance Hall sensor and copper insulation between the valve body $100M\Omega$ or more. (DC 500V)
- 10, heat resistance in 80 ± 3 °C environment placed 48h, return to normal temperature 1-2h no abnormalities, and parts without cracks, relaxation, expansion, deformation and other phenomena, the accuracy of change within 10%.
- 11, cold resistance in the -20 ± 3 °C environment placed 48h, return to normal temperature 1-2h no abnormalities, and parts without cracks, relaxation, swelling, deformation and other phenomena, accuracy changes within 10%.
- 12, moisture resistance at 40 ± 2 °C, relative humidity 90% ~ 95% RH environment placed 72h removed, the insulation resistance $1M\Omega$ above.
- 13, pull-out strength in the lead-line applied 1N10N pull, no loose, pull off phenomenon, and no change in performance.
- 14, durability at room temperature, from the inlet into the 0.1MPa water pressure to connect 1S, 0.5S off for a cycle,
Test 300,000 times without exception.

| Flow - Refer to the table of pulse characteristics | | | | | | | | | |
|--|-------|-------------|------|------|------|-------|-----------|------|------|
| Flow | Pulse | Error | Min | Max | Flow | Pulse | Error | Min | Max |
| 2 | 15 | ± 1.020 | 15.3 | 14.7 | 6.1 | 45.8 | ± 3.2 | 47.1 | 44.4 |
| 2.1 | 15.75 | ± 1.021 | 16.1 | 15.4 | 6.2 | 46.5 | ± 3.3 | 47.9 | 45.1 |
| 2.2 | 16.5 | ± 1.022 | 16.8 | 16.2 | 6.3 | 47.3 | ± 3.4 | 48.7 | 45.8 |
| 2.3 | 17.25 | ± 1.023 | 17.6 | 16.9 | 6.4 | 48.0 | ± 3.5 | 49.4 | 46.6 |
| 2.4 | 18 | ± 1.024 | 18.4 | 17.6 | 6.5 | 48.8 | ± 3.6 | 50.2 | 47.3 |
| 2.5 | 18.75 | ± 1.025 | 19.1 | 18.4 | 6.6 | 49.5 | ± 3.7 | 51.0 | 48.0 |

| | | | | | | | | | |
|-----|-------|--------|------|------|---|------|-------|------|------|
| 2.6 | 19.5 | ±1.026 | 19.9 | 19.1 | 6.7 | 50.3 | ±3.8 | 51.8 | 48.7 |
| 2.7 | 20.25 | ±1.027 | 20.7 | 19.8 | 6.8 | 51.0 | ±3.9 | 52.5 | 49.5 |
| 2.8 | 21 | ±1.028 | 21.4 | 20.6 | 6.9 | 51.8 | ±3.10 | 53.3 | 50.2 |
| 2.9 | 21.75 | ±1.029 | 22.2 | 21.3 | 7 | 52.5 | ±3.11 | 54.1 | 50.9 |
| 3 | 22.5 | ±1.030 | 23.0 | 22.1 | 7.1 | 53.3 | ±3.12 | 54.8 | 51.7 |
| 3.1 | 23.25 | ±1.031 | 23.7 | 22.8 | 7.2 | 54.0 | ±3.13 | 55.6 | 52.4 |
| 3.2 | 24 | ±1.032 | 24.5 | 23.5 | 7.3 | 54.8 | ±3.14 | 56.4 | 53.1 |
| 3.3 | 24.75 | ±1.033 | 25.2 | 24.3 | 7.4 | 55.5 | ±3.15 | 57.2 | 53.8 |
| 3.4 | 25.5 | ±1.034 | 26.0 | 25.0 | 7.5 | 56.3 | ±3.16 | 57.9 | 54.6 |
| 3.5 | 26.25 | ±1.035 | 26.8 | 25.7 | 7.6 | 57.0 | ±3.17 | 58.7 | 55.3 |
| 3.6 | 27 | ±1.036 | 27.5 | 26.5 | 7.7 | 57.8 | ±3.18 | 59.5 | 56.0 |
| 3.7 | 27.75 | ±1.037 | 28.3 | 27.2 | 7.8 | 58.5 | ±3.19 | 60.3 | 56.7 |
| 3.8 | 28.5 | ±1.038 | 29.1 | 27.9 | 7.9 | 59.3 | ±3.20 | 61.0 | 57.5 |
| 3.9 | 29.25 | ±1.039 | 29.8 | 28.7 | 8 | 60.0 | ±3.21 | 61.8 | 58.2 |
| 4 | 30 | ±1.040 | 30.6 | 29.4 | 8.1 | 60.8 | ±3.22 | 62.6 | 58.9 |
| 4.1 | 30.75 | ±1.041 | 31.4 | 30.1 | 8.2 | 61.5 | ±3.23 | 63.3 | 59.7 |
| 4.2 | 31.5 | ±1.042 | 32.1 | 30.9 | 8.3 | 62.3 | ±3.24 | 64.1 | 60.4 |
| 4.3 | 32.25 | ±1.043 | 32.9 | 31.6 | 8.4 | 63.0 | ±3.25 | 64.9 | 61.1 |
| 4.4 | 33 | ±1.044 | 33.7 | 32.3 | 8.5 | 63.8 | ±3.26 | 65.7 | 61.8 |
| 4.5 | 33.75 | ±1.045 | 34.4 | 33.1 | 8.6 | 64.5 | ±3.27 | 66.4 | 62.6 |
| 4.6 | 34.5 | ±1.046 | 35.2 | 33.8 | 8.7 | 65.3 | ±3.28 | 67.2 | 63.3 |
| 4.7 | 35.25 | ±1.047 | 36.0 | 34.5 | 8.8 | 66.0 | ±3.29 | 68.0 | 64.0 |
| 4.8 | 36 | ±1.048 | 36.7 | 35.3 | 8.9 | 66.8 | ±3.30 | 68.8 | 64.7 |
| 4.9 | 36.75 | ±1.049 | 37.5 | 36.0 | 9 | 67.5 | ±3.31 | 69.5 | 65.5 |
| 5 | 37.5 | ±1.050 | 38.3 | 36.8 | 9.1 | 68.3 | ±3.32 | 70.3 | 66.2 |
| 5.1 | 38.25 | ±1.051 | 39.0 | 37.5 | 9.2 | 69.0 | ±3.33 | 71.1 | 66.9 |
| 5.2 | 39 | ±1.052 | 39.8 | 38.2 | 9.3 | 69.8 | ±3.34 | 71.8 | 67.7 |
| 5.3 | 39.75 | ±1.053 | 40.5 | 39.0 | 9.4 | 70.5 | ±3.35 | 72.6 | 68.4 |
| 5.4 | 40.5 | ±1.054 | 41.3 | 39.7 | 9.5 | 71.3 | ±3.36 | 73.4 | 69.1 |
| 5.5 | 41.25 | ±1.055 | 42.1 | 40.4 | 9.6 | 72.0 | ±3.37 | 74.2 | 69.8 |
| 5.6 | 42 | ±1.056 | 42.8 | 41.2 | 9.7 | 72.8 | ±3.38 | 74.9 | 70.6 |
| 5.7 | 42.75 | ±1.057 | 43.6 | 41.9 | 9.8 | 73.5 | ±3.39 | 75.7 | 71.3 |
| 5.8 | 43.5 | ±1.058 | 44.4 | 42.6 | 9.9 | 74.3 | ±3.40 | 76.5 | 72.0 |
| 5.9 | 44.25 | ±1.059 | 45.1 | 43.4 | 10 | 75.0 | ±3.41 | 77.3 | 72.8 |
| 6 | 45 | ±1.060 | 45.9 | 44.1 | Note: Pulse (Hz) = [7.5x Flow Rate Q (L / min)] ± 3% | | | | |

All Dimensions are in mm

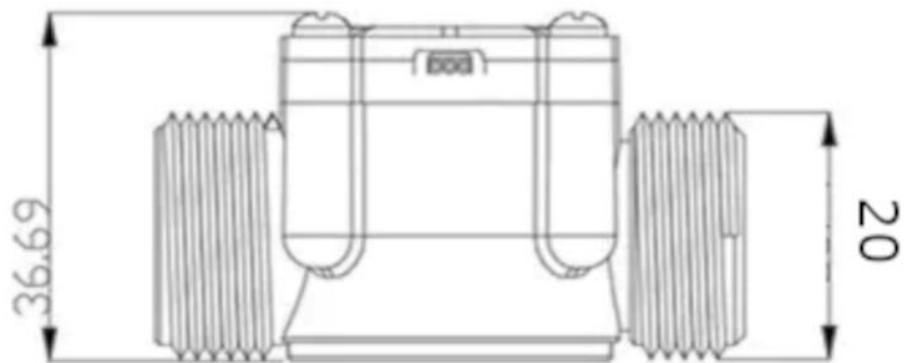
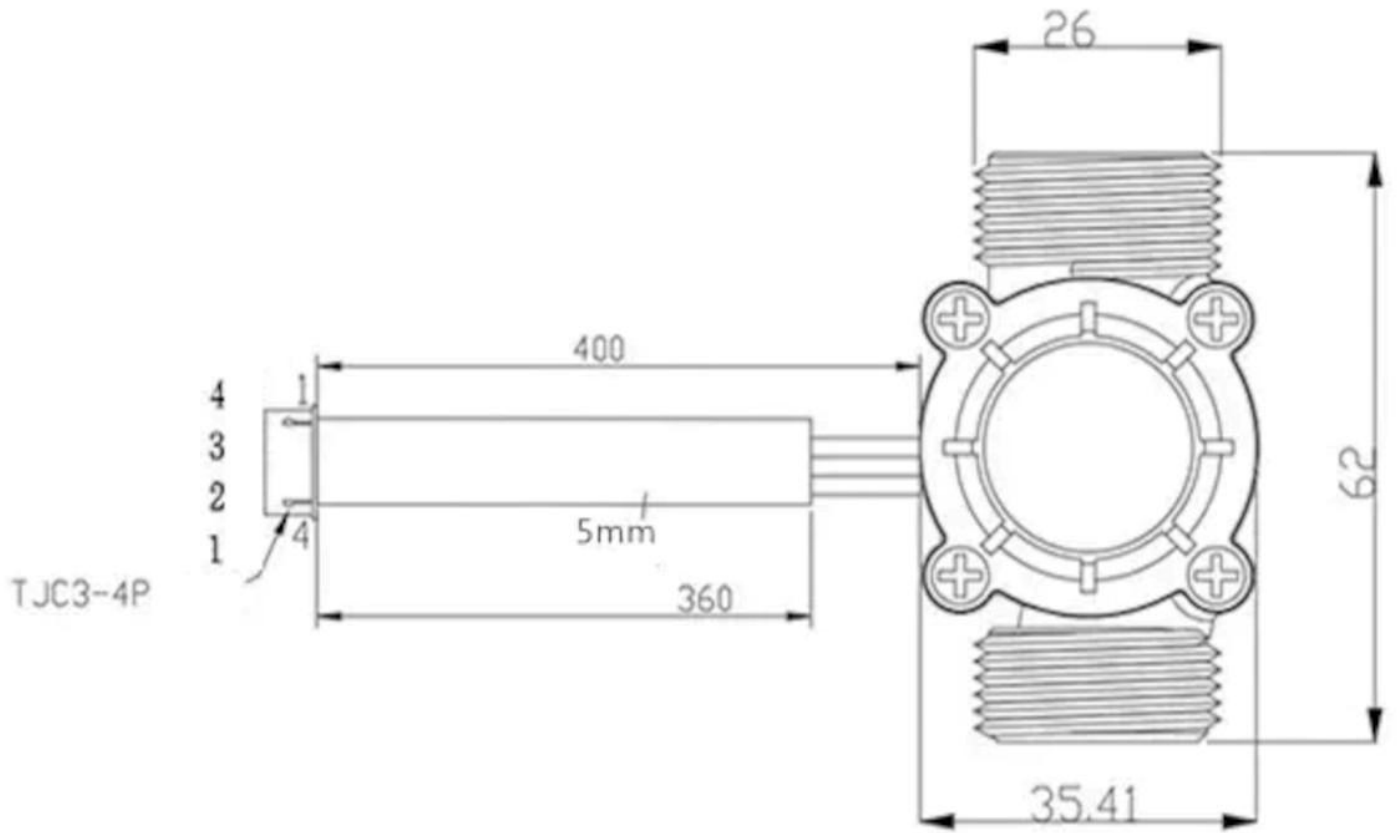

Wiring Interface

