



Ai-WB2-13 Specification

Version V1.1.0

Copyright ©2022

Content

1. Product Overview	4
1.1. Characteristic	5
2. Main parameters	6
2.1. Static electricity requirement	6
2.2. Electrical characteristics	7
2.3. Wi-Fi RF Performance	7
2.4. BLE RF Performance	8
2.5. Power	8
3. Appearance Dimensions	9
4. Pin Definition	10
5. Schematic	12
6. Antenna parameters	13
6.1. Schematic diagram of the antenna test prototype	13
6.2. Antenna S parameter	14
6.3. Antenna Gain and Efficiency	14
6.4. Antenna pattern	15
7. Design Guidance	16
7.1. Application circuit	16
7.2. Antenna layout requirements	16
7.3. Power supply	17
7.4. GPIO	18
8. Storage conditions	19
9. Reflow welding curve diagram	19
10. Product related models	20
11. Product Packaging Information	21
12. Contact us	21
Disclaimer and copyright notice	22
Notice	22

1. Product Overview

Ai-WB2-13 is a Wi-Fi& BT module developed by Shenzhen Ai-Thinker Technology Co., LTD. The module is equipped with BL602 chip as the core processor and supports Wi-Fi 802.11b/g/n protocol and BLE 5.0 protocol. The BL602 chip has a low-power 32-bit RISC CPU, 276KB RAM, and a wealth of peripheral interfaces, including SDIO, SPI, UART, I2C, IR Remote, PWM, ADC, DAC, PIR and GPIO. It can be widely used in Internet of Things (IoT), mobile devices, wearable electronic devices, smart home and other fields.

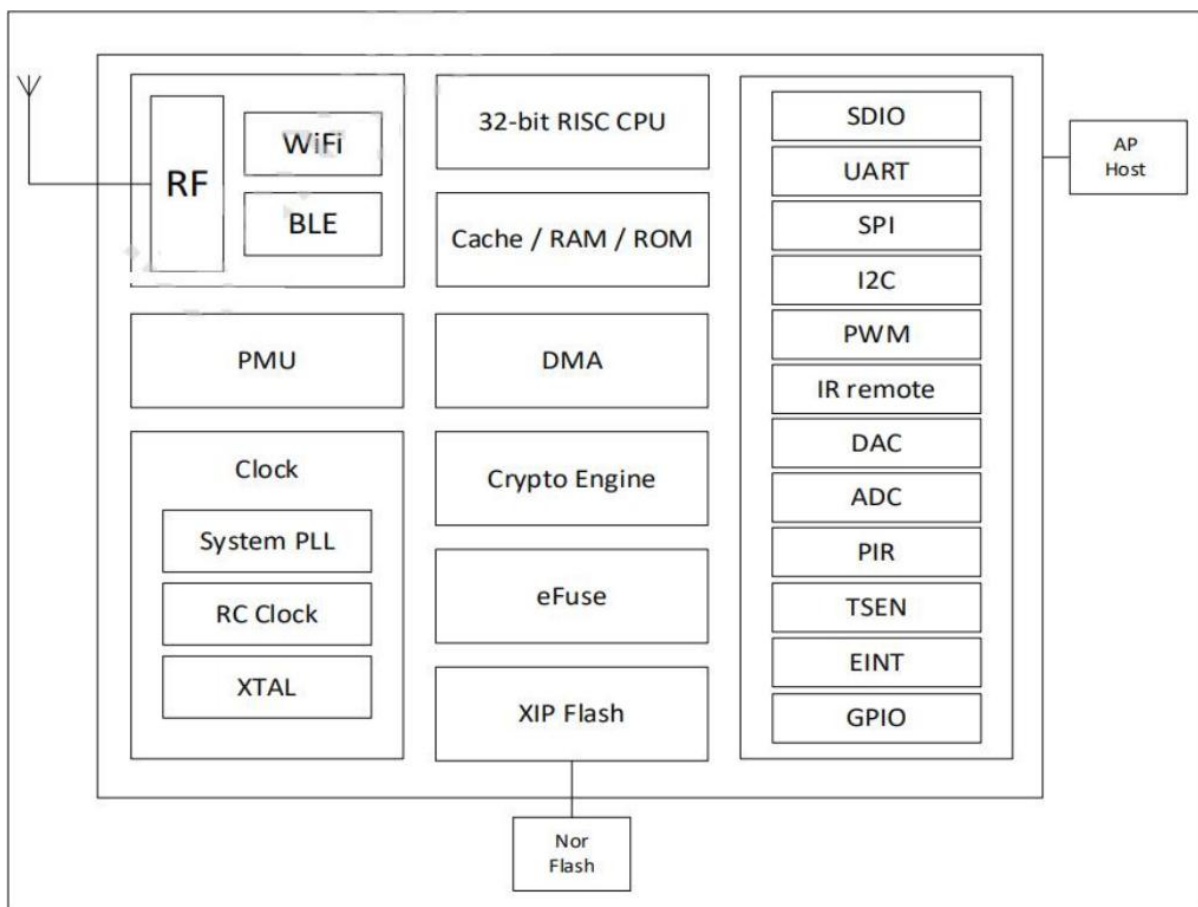

Figure 1 Main chip architecture diagram

1.1. Characteristic

- The package is SMD-18
- Support IEEE 802.11 b/g/n protocol
- Wi-Fi Security Support WPS/WEP/WPA/WPA2 Personal/WPA2 Enterprise/WPA3
- Support 20MHz bandwidth and Max rate is 72.2 Mbps
- Bluetooth BLE 5.0, Bluetooth Mesh
- Support Station + BLE、 Station + SoftAP + BLE
- Support 32-bit RISC CPU, 276KB RAM
- Secure startup, supports mirroring with ECC-256 signature
- Support QSPI/SPI Flash On-The-Fly AES Decryption (OTFAD), support AES 128 CTR
- Support AES 128/192/256-bit encryption engine
- Support SHA-1/224/256
- Support true Random number generator (TRNG)
- Public key Accelerator (PKA), support large number basic operations, software provides signature, verification and other application program interface
- Support SDIO, SPI, UART, I2C, IR remote, PWM, ADC, DAC, PIR, GPIO etc
- Integrated Wi-Fi MAC/BB/RF/PA/LNA/BT
- Support a variety of sleep modes, deep sleep current 12 μ A
- Universal AT instruction for quick start
- Support secondary development, integrated Windows, Linux development environment

2. Main parameters

Table 1 Description of the main parameters

Model	Ai-WB2-13
Package	SMD-18
Size	20.0*18.0*3.1(±0.2)mm
Antenna	on-board PCB antenna
Frequency	2400 ~ 2483.5MHz
Operating temperature	-40°C ~ 85°C
Storage temperature	-40°C ~ 125°C, < 90%RH
Power supply	Support voltage 2.7V ~ 3.6V, supply current ≥500mA
Interface	UART/GPIO/ADC/PWM/I2C/SPI
IO	11
UART rate	Default 115200 bps
Security	WPS/WEP/WPA/WPA2 Personal/WPA2 Enterprise/WPA3
Flash	Default 4MByte, MAX support 16MByte

2.1. Static electricity requirement

Ai-WB2-13 is an electrostatic sensitive device. Therefore, you need to take special precautions when carrying it.



Figure 2 ESD preventive measures

2.2. Electrical characteristics

Table 2 Electrical characteristics table

Parameters	Condition	Min.	Typical value	Max.	Unit
Voltage Supply	VDD	2.7	3.3	3.6	V
I/O	VIL	-	-	0.3*VDDIO	V
	VIH	-	0.7*VDDIO	-	V
	VOL	-	-	0.1*VDDIO	V
	VOH	-	-	0.9*VDDIO	V
	IMAX	-	-	-	15

2.3. Wi-Fi RF Performance

Table 3 Wi-Fi RF performance table

Description	Typical value			Unit
Frequency range	2400 ~ 2483.5MHz			MHz
Output Power				
Mode	Min.	Typical value	Max.	Unit
11n Mode HT20, PA output power	-	16	-	dBm
11g Mode, PA output power	-	17	-	dBm
11b Mode, PA output power	-	19	-	dBm
Receive Sensitivity				
Mode	Min.	Typical value	Max.	Unit
11b, 1 Mbps	-	-98	-	dBm
11b, 11 Mbps	-	-90	-	dBm
11g, 6 Mbps	-	-93	-	dBm
11g, 54 Mbps	-	-76	-	dBm
11n, HT20 (MCS7)	-	-73	-	dBm

2.4. BLE RF Performance

Table 4 BLE RF performance table

Description	Typical value			Unit
Frequency range	2400 ~ 2483.5MHz			MHz
Output Power				
Rate Mode	Min.	Typical value	Max.	Unit
1Mbps	-	9	15	dBm
Receive Sensitivity				
Rate Mode	Min.	Typical value	Max.	Unit
1Mbps sensitivity@30.8%PER	-	-96	-	dBm

2.5. Power

The following power consumption data are based on a 3.3V power supply, 25°C ambient temperature, and measured using an internal voltage regulator.

- All measurements are made at the antenna interface with a filter.
- All transmission data are based on 100% duty cycle in continuous transmission mode.

Table 5 Power consumption

Mode	Min.	AVG	Max.	Unit
Tx 802.11b, 11Mbps, POUT=+21dBm	-	260	-	mA
Tx802.11g, 54Mbps, POUT =+18dBm	-	245	-	mA
Tx802.11n, MCS7, POUT =+17dBm	-	230	-	mA
Rx 802.11b,packet length 1024 byte	-	65	-	mA
Rx 802.11g,packet length 1024 byte	-	65	-	mA
Rx 802.11n,Packet length 1024 byte	-	65	-	mA
Deep-Sleep	-	12	-	μA

3. Appearance Dimensions

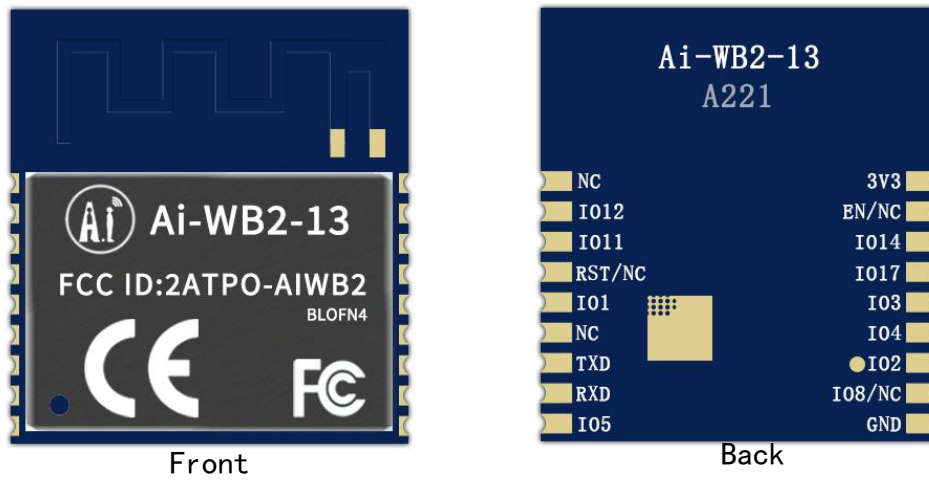

Figure 3 Appearance diagram (pictures is for reference only,subject to physical objects)

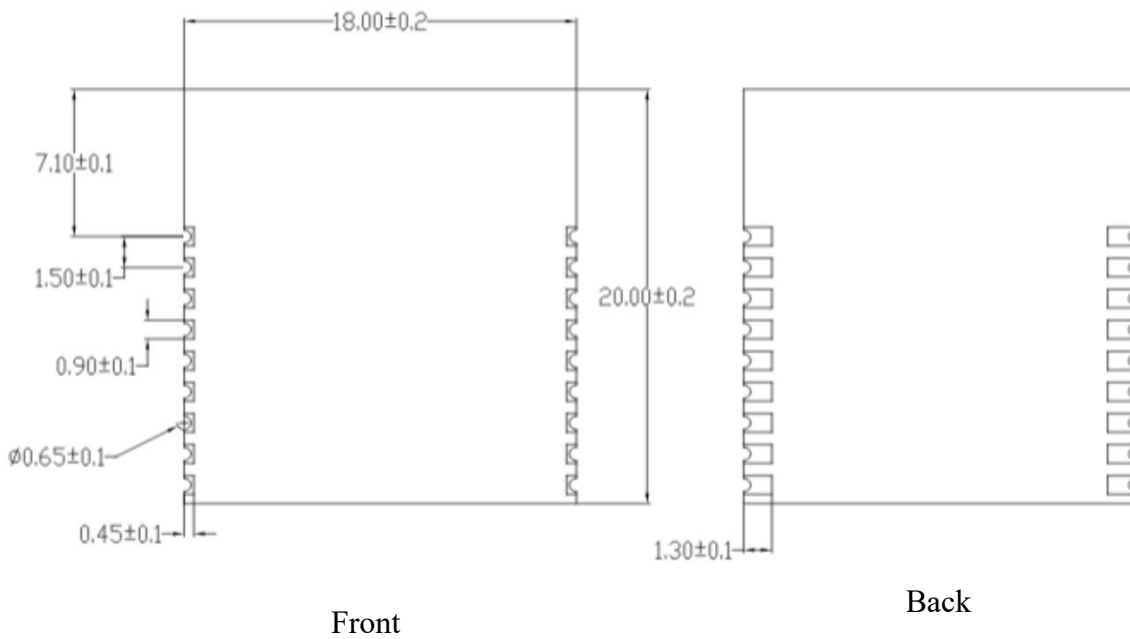

Figure 4 Dimension diagram

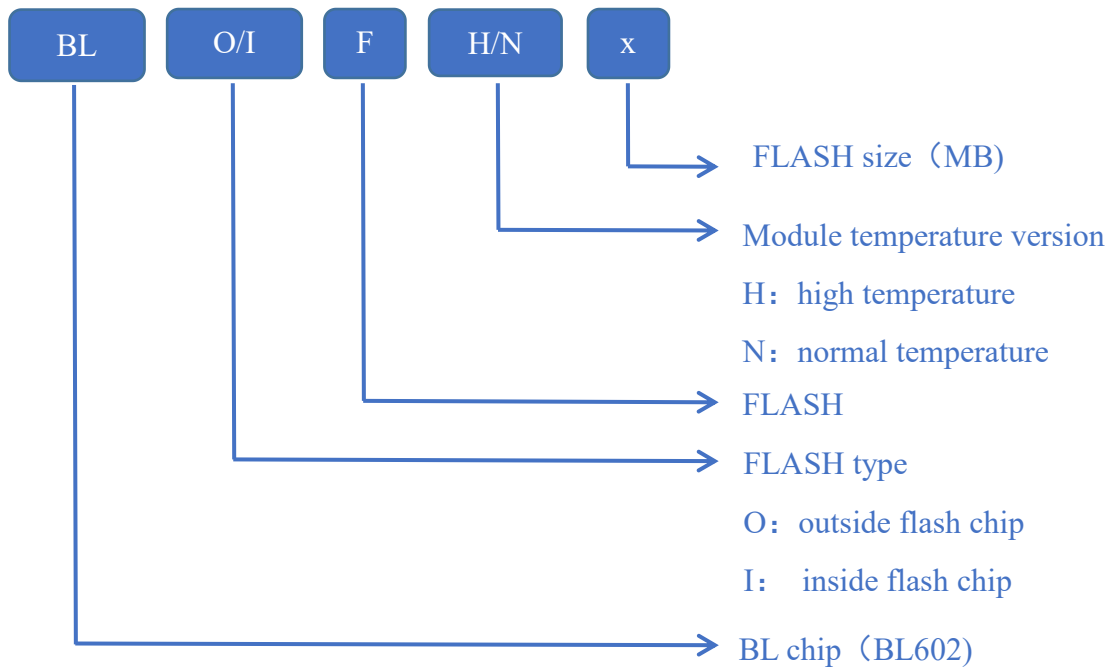

Figure 5. Naming of module information

4. Pin Definition

Ai-WB2-13 module is connected with a total of 18 pins, as shown in the pin schematic diagram, pin function definition table is the interface definition.

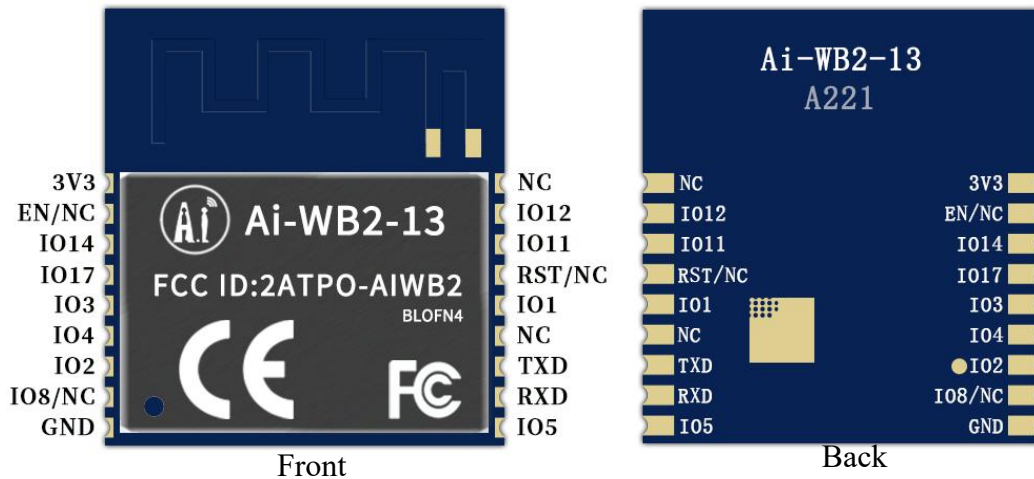
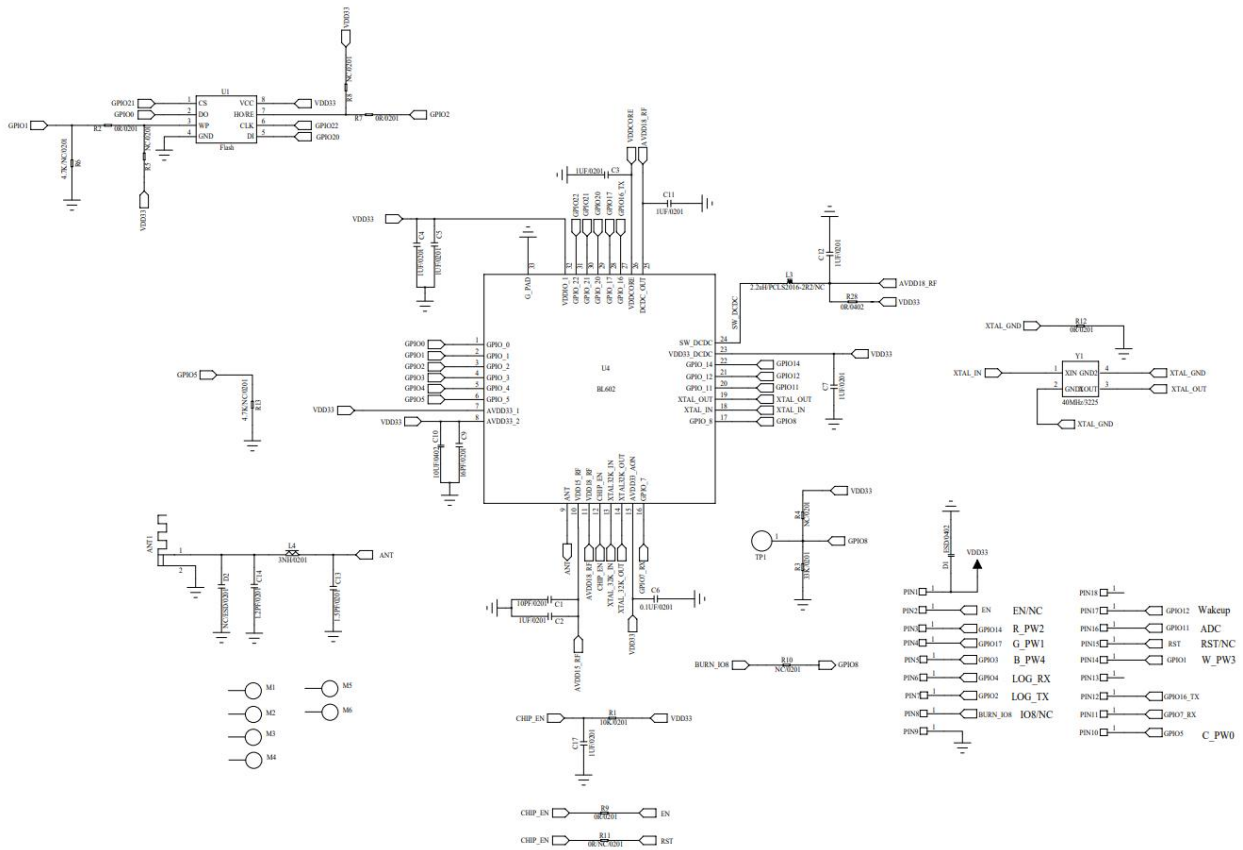

Figure 6 Schematic diagram of module pins

Table 6 Pin function definition table

No.	Name	Function
1	3V3	3.3V power supply; It is recommended that the output current of the external power supply be higher than 500mA
2	EN/NC	Default chip enable pin, active-high, cannot be used with RST at the same time
3	IO14	GPIO14/SPI_SS/IIC_SCL/PWM_CH4/ADC_CH2
4	IO17	GPIO17/SPI_MOSI/MISO/IIC_SDA/PWM_CH2
5	IO3	GPIO3/SPI_SCLK/IIC_SDA/PWM_CH3
6	IO4	GPIO4/SPI_MOSI/MISO/IIC_SCL/PWM_CH4/ADC_CH4
7	IO2	It is not recommended to use. It is shared with the Flash in the module. If you need to use it, please contact Ai-Thinker. GPIO2/SPI_SS/IIC_SCL/PWM_CH2
8	IO8/NC	Default NC, unavailable
9	GND	Ground
10	IO5	GPIO5/SPI_MOSI/MISO/IIC_SDA/PWM_CH0/ADC_CH4
11	RXD	RXD/GPIO7/SPI_SCLK/IIC_SDA/PWM_CH2
12	TXD	TXD/GPIO16/SPI_MOSI/MISO/IIC_SCL/PWM_CH1
13	NC	Ground
14	IO1	It is not recommended to use. It is shared with the Flash in the module. If you need to use it, please contact Ai-Thinker. GPIO1/SPI_MOSI/MISO/IIC_SDA/PWM_CH1
15	RST/NC	Default not connect, can be customized to reset pin, active-low, if you need to use it, please contact Ai-Thinker
16	IO11	GPIO11/SPI_SCLK/IIC_SDA/ADC_CH10
17	IO12	GPIO12/SPI_MOSI/MISO/IIC_SCL/PWM_CH2/ADC_CH0
18	NC	Ground

5. Schematic



6. Antenna parameters

6.1. Schematic diagram of the antenna test prototype

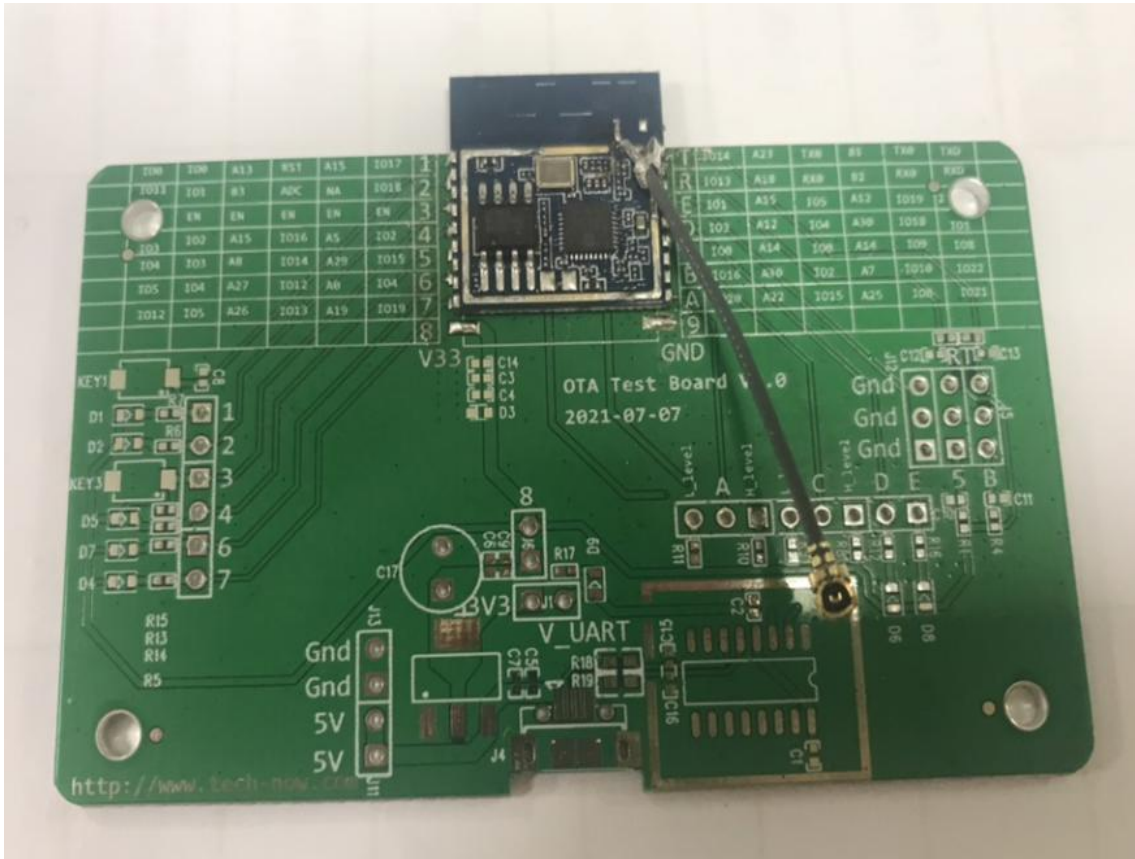

Figure 8 Schematic diagram of the antenna test prototype

6.2. Antenna S parameter

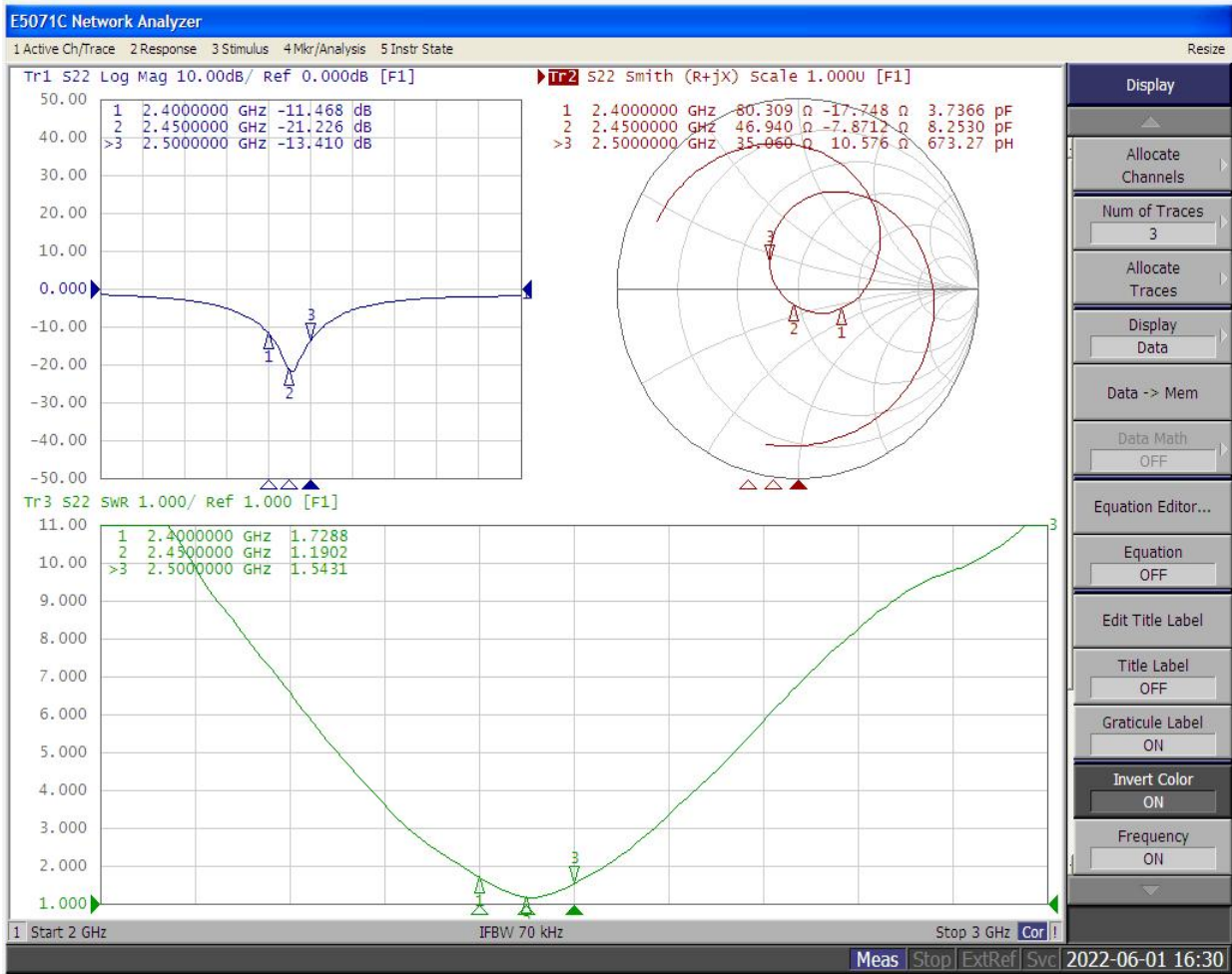

Figure 9 Antenna S parameters

6.3. Antenna Gain and Efficiency

Table 7 Antenna Gain and efficiency

Frequency ID	1	2	3	4	5	6	7	8	9	10	11
Frequency(MHz)	2400	2410	2420	2430	2440	2450	2460	2470	2480	2490	2500
Gain (dBi)	2.36	2.38	2.15	2.25	2.06	2.49	2.46	2.44	2.42	2.13	2.30
Efficiency (%)	70.35	70.39	67.97	69.50	65.53	71.32	70.92	69.44	67.91	61.87	61.11

6.4. Antenna pattern

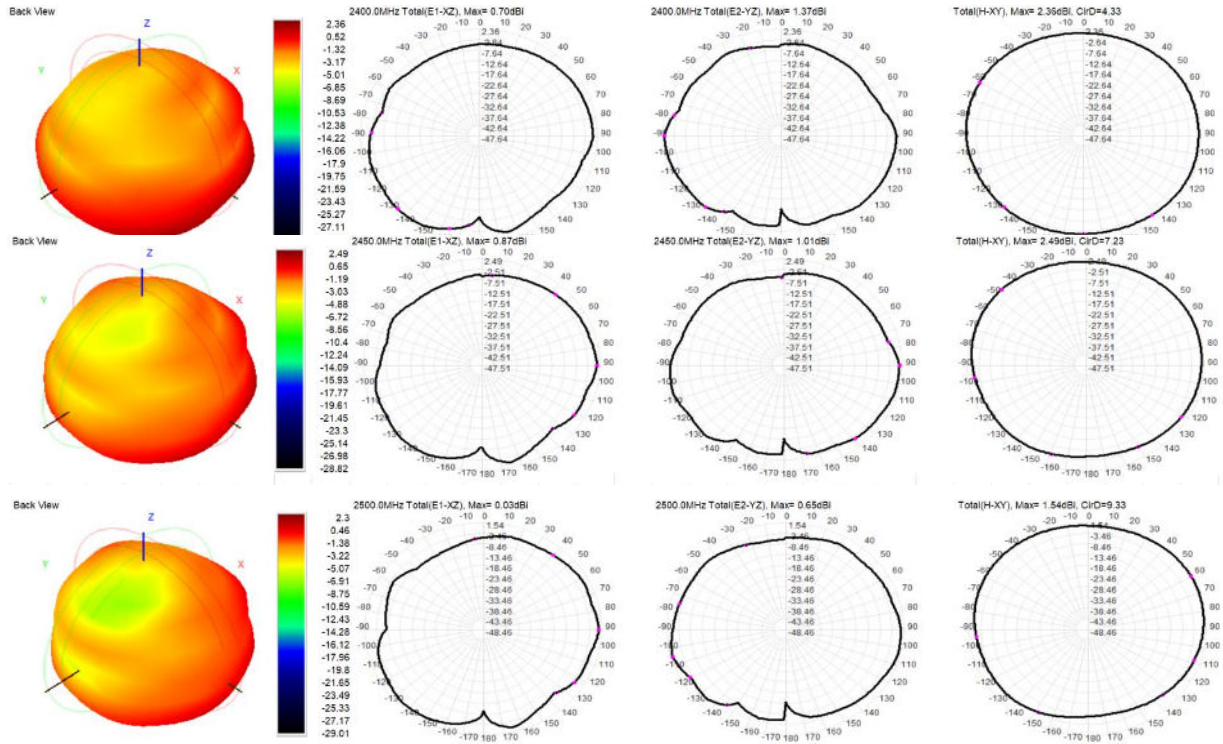

Figure 10 Antenna pattern

7. Design Guidance

7.1. Application circuit

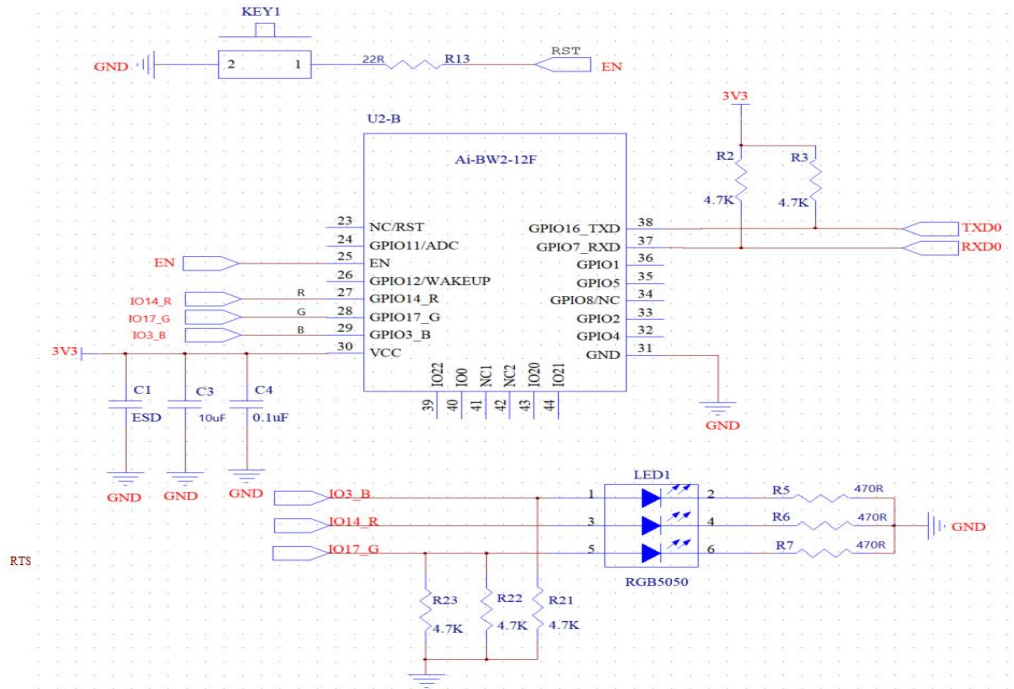

Figure 11 Application circuit diagram

- If the IO port is used as PWM, it is recommended to reserve a 4.7K pull-down resistor around the module. Especially in the application of light control, it can prevent the flashing light phenomenon at the moment of power-on start.
- GPIO1/GPIO2/GPIO8/RST pins, which are not available by default. If you need to use it, please contact Ai-Thinker.

7.2. Antenna layout requirements

- The following two methods are recommended for the installation position on the mainboard:

Option 1: put the module on the edge of the motherboard, and the antenna area extends out of the edge of the motherboard.

Option 2: put the module on the edge of the motherboard, the edge of the motherboard at the antenna position hollowed out an area.

- In order to meet the performance of onboard antenna, it is forbidden to place metal parts around the antenna and keep away from high frequency devices.

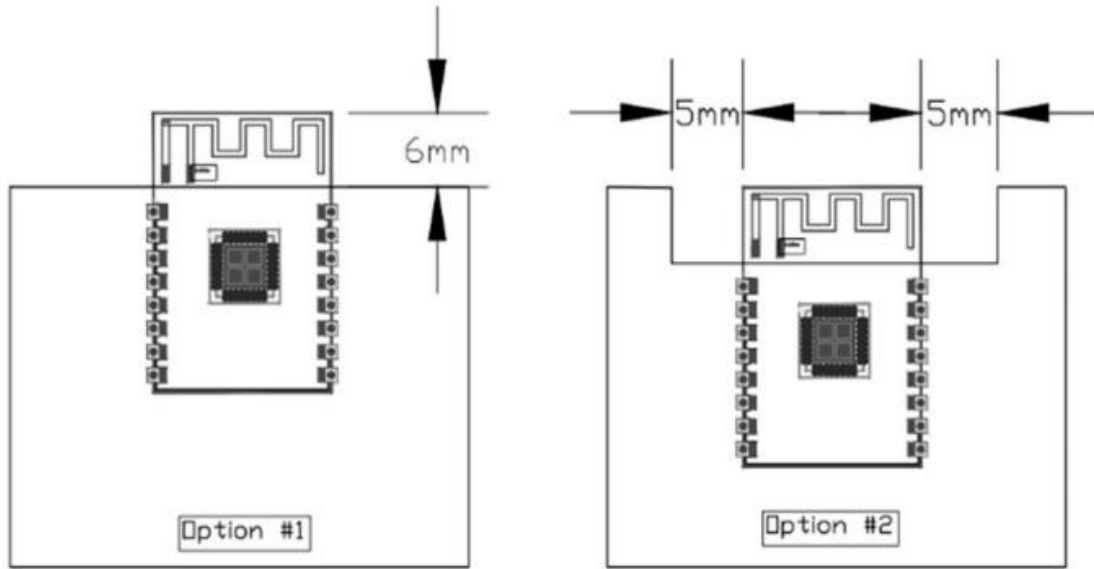

Figure 12 Antenna layout diagram

7.3. Power supply

- Recommended 3.3V voltage, peak current over 500mA.
- Power supply is recommend to use LDO; if the DC-DC is used, the ripple is recommended to be controlled within 30mV
- DC-DC power supply circuit proposes to reserve the dynamic response capacitance to optimize the output ripple with large load changes.
- It is recommended to add ESD devices to the 3.3V power interface.

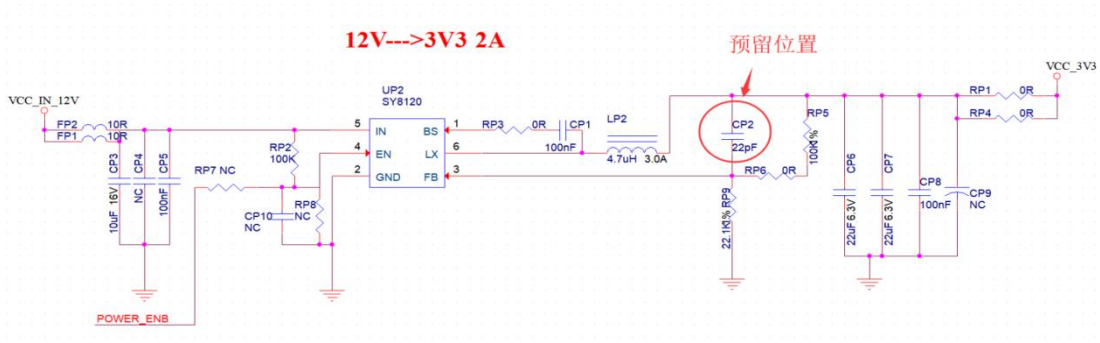

Figure 13 DC-DC step-down circuit diagram

7.4. GPIO

- There are some IO ports on the periphery of the module. If you need to use it, it is recommended to connect a 10-100 ohm resistor in series with the IO port. This inhibits overshoot and makes both sides level more stable. It is helpful for EMI and ESD.
- For special I/O ports to be pulled up and down, refer to the usage instructions in the specifications, which may affect the module startup configuration.
- The IO port of the module is 3.3V. If the IO level of the main control and the module do not match, a level conversion circuit needs to be added.
- If the I/O port is directly connected to a peripheral port or terminals, for example, a pin row, reserve an ESD device near the terminal of the I/O cable.

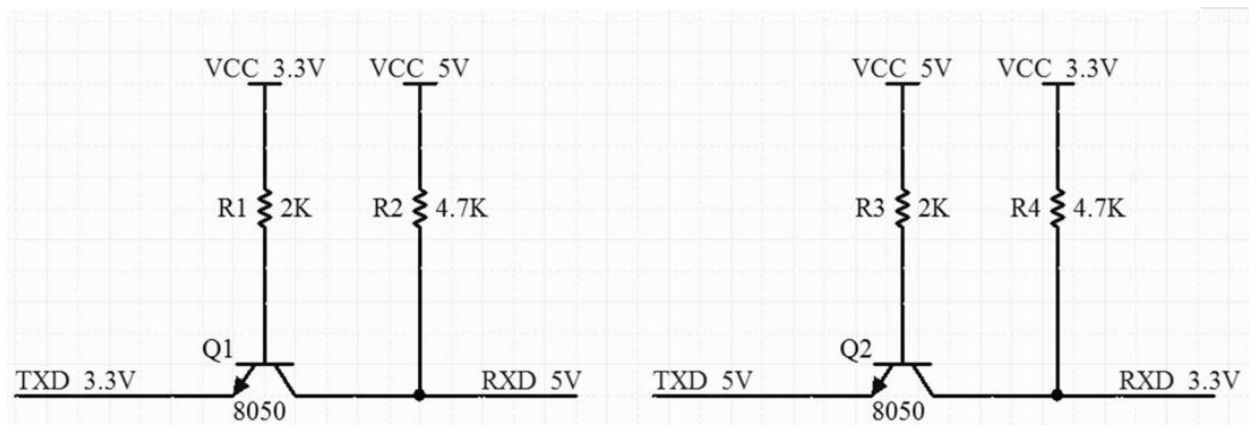

Figure 14 Level convert circuit

8. Storage conditions

Products sealed in moisture-proof bags should be stored in a non-condensing atmosphere of $<40^{\circ}\text{C} / 90\%RH$.

The module has a moisture sensitivity rating of MSL 3.

After the vacuum bag is opened, it must be used within 168 hours at $25\pm 5^{\circ}\text{C} / 60\%RH$, otherwise it needs to be baked before it can be put on line again.

9. Reflow welding curve diagram

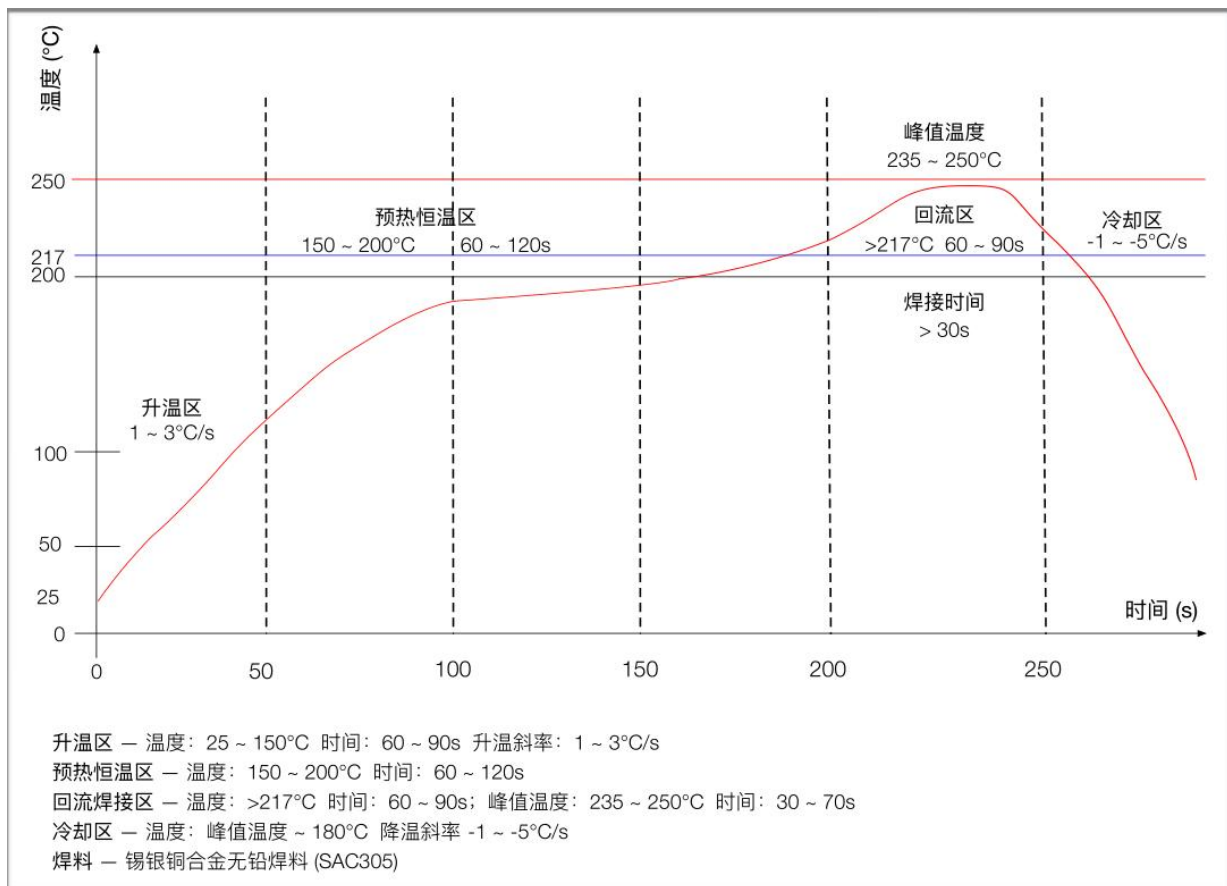

Figure 15 Reflow welding diagram

10. Product related models

Table 8 Product related model list

Model	Power Supply	Package	Size	Antenna
Ai-WB2-12S	2.7V ~ 3.6V, $I \geq 500\text{mA}$	SMD-16	24.0*16.0*3.1±0.2)mm	on-board PCB antenna
Ai-WB2-12F	2.7V ~ 3.6V, $I \geq 500\text{mA}$	SMD-22	24.0*16.0*3.1±0.2)mm	on-board PCB antenna
Ai-WB2-07S	2.7V ~ 3.6V, $I \geq 500\text{mA}$	SMD-22	17.0*16.0*3.1±0.2)mm	IPEX interface
Ai-WB2-13	2.7V ~ 3.6V, $I \geq 500\text{mA}$	SMD-18	20.0*18.0*3.1±0.2)mm	on-board PCB antenna
Ai-WB2-13U	2.7V ~ 3.6V, $I \geq 500\text{mA}$	SMD-18	14.0*18.0*3.1±0.2)mm	IPEX interface
Ai-WB2-32S	2.7V ~ 3.6V, $I \geq 500\text{mA}$	SMD-38	25.5*18.0*3.1±0.2)mm	Default onboard PCB antenna/compatible IPEX interface
Ai-WB2-01M	2.7V ~ 3.6V, $I \geq 500\text{mA}$	DIP-18	18.0*18.0*2.8±0.2)mm	on-board PCB antenna
Ai-WB2-12F-Kit	3.3V or 5V, $I > 500\text{mA}$	DIP-30	49.66*25.4(±0.2)mm	on-board PCB antenna
Ai-WB2-13-Kit	3.3V or 5V, $I > 500\text{mA}$	DIP-30	49.66*25.4(±0.2)mm	on-board PCB antenna
Ai-WB2-32S-Kit	3.3V or 5V, $I > 500\text{mA}$	DIP-38	55.05*25.4(±0.2)mm	on-board PCB antenna
Product related information : https://docs.ai-thinker.com				

11. Product Packaging Information

Ai-WB2-13 module was packaged in a tape, 650pcs/reel. As shown in the below image:

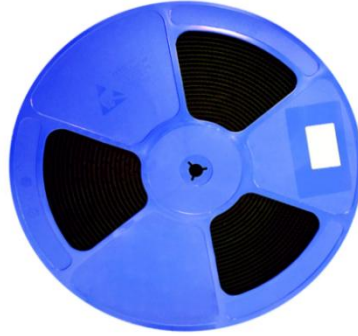

Figure 15 Package and packing diagram

12. Contact us

[Ai-Thinker official website](#)

[Office forum](#)

[Develop DOCS](#)

[LinkedIn](#)

[Tmall shop](#)

[Taobao shop](#)

[Alibaba shop](#)

[Technical support email: support@aithinker.com](mailto:support@aithinker.com)

[Domestic business cooperation: sales@aithinker.com](mailto:sales@aithinker.com)

[Overseas business cooperation: overseas@aithinker.com](mailto:overseas@aithinker.com)

Company Address: Room 403,408-410, Block C, Huafeng Smart Innovation Port, Gushu 2nd Road, Xixiang, Baoan District, Shenzhen.

Tel: +86-0755-29162996



WeChat mini program



WeChat official account

Disclaimer and copyright notice

The information in this article, including the URL address for reference, is subject to change without notice.

The document is provided "as is" without any guarantee responsibility, including any guarantee for merchantability, suitability for a specific purpose, or non-infringement, and any guarantee mentioned elsewhere in any proposal, specification or sample. This document does not bear any responsibility, including the responsibility for infringement of any patent rights arising from the use of the information in this document. This document does not grant any license for the use of intellectual property rights in estoppel or other ways, whether express or implied.

The test data obtained in the article are all obtained from Ai-Thinker's laboratory tests, and the actual results may vary slightly.

All brand names, trademarks and registered trademarks mentioned in this article are the property of their respective owners, and it is hereby declared.

The final interpretation right belongs to Shenzhen Ai-Thinker Technology Co., Ltd.

Notice

Due to product version upgrades or other reasons, the contents of this manual may be changed.

Shenzhen Ai-Thinker Technology Co., Ltd. reserves the right to modify the contents of this manual without any notice or prompt.

This manual is only used as a guide. Shenzhen Ai-Thinker Technology Co., Ltd. makes every effort to provide accurate information in this manual. However, Shenzhen Ai-Thinker Technology Co., Ltd. does not guarantee that the contents of the manual are completely free of errors. All statements and information in this manual And the suggestion does not constitute any express or implied guarantee.