



ESP-12S Datasheet

Version V1

Copyright ©2018

Disclaimer and Copyright Notice

Information in this document, including URL references, is subject to change without notice.

THIS DOCUMENT IS PROVIDED AS IS WITH NO WARRANTIES WHATSOEVER, INCLUDING ANY WARRANTY OF MERCHANTABILITY, NON-INFRINGEMENT, FITNESS FOR ANY PARTICULAR PURPOSE, OR ANY WARRANTY OTHERWISE ARISING OUT OF ANY PROPOSAL, SPECIFICATION OR SAMPLE.

All liability, including liability for infringement of any proprietary rights, relating to use of information in this document is disclaimed. No licenses express or implied, by estoppel or otherwise, to any intellectual property rights are granted herein.

The test data obtained in this paper are all tested by Ai-Thinker lab, and the actual results may be slightly different.

The Wi-Fi Alliance Member logo is a trademark of the Wi-Fi Alliance. The Bluetooth logo is a registered trademark of Bluetooth SIG.

All trade names, trademarks and registered trademarks mentioned in this document are property of their respective owners, and are hereby acknowledged.

The final interpretation is owned by Shenzhen Ai-Thinker Technology Co., Ltd.

1. Product overview

The ESP-12S WiFi module was developed by Ai-Thinker Technology. The core processor ESP8266 integrates the industry-leading Tensilica L106 ultra-low-power 32-bit micro MCU in a small package with 16-bit Lite mode, clocked at Supports 80 MHz and 160 MHz, supports RTOS, and integrates Wi-Fi MAC/BB/RF/PA/LNA.

The ESP-12S WiFi module supports the standard IEEE802.11 b/g/n protocol, a complete TCP/IP protocol stack. Users can use this module to add networking capabilities to existing devices or to build separate network controllers.

The ESP8266 is a high-performance wireless SOC that offers maximum utility at the lowest cost and unlimited possibilities for embedding WiFi functionality into other systems.

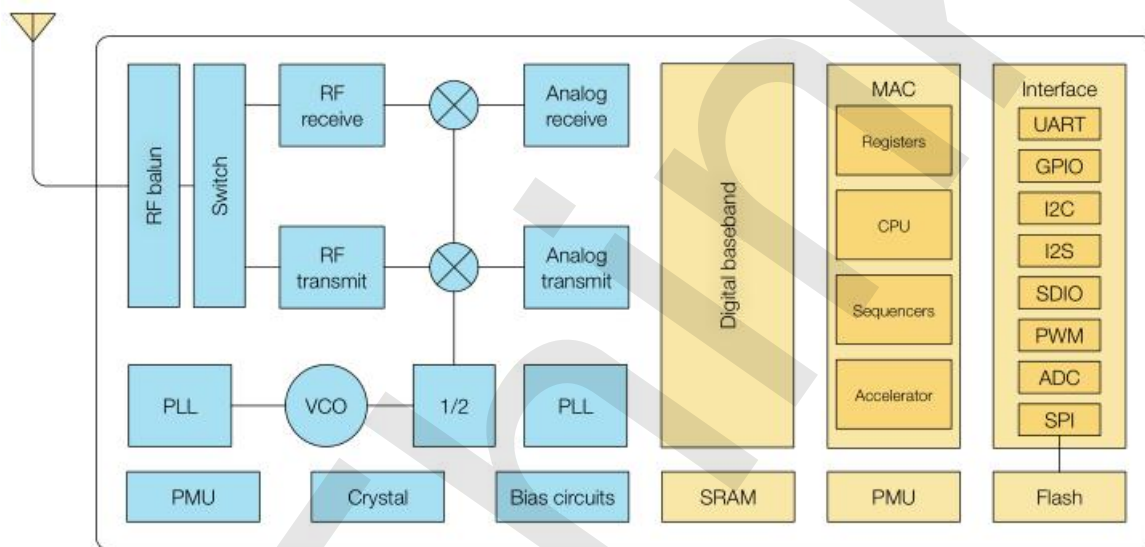

The ESP8266 is a complete and self-contained WiFi network solution that can operate independently or as a slave running on other host MCUs. The ESP8266 is capable of booting directly from an external flash memory when it is powered by an application and is the only application processor in the device. The built-in cache helps improve system performance and reduce memory requirements.

In another case, the ESP8266 is responsible for wireless Internet access. When it comes to the task of the WiFi adapter, it can be added to any micro controller-based design. The connection is simple and easy, just by SPI / SDIO interface or I2C / UART port. Just fine.

The ESP8266's powerful on-chip processing and storage capabilities allow it to integrate sensors and other application-specific devices through the GPIO port, minimizing system resources during minimal up-front development and operation.

Appearance size

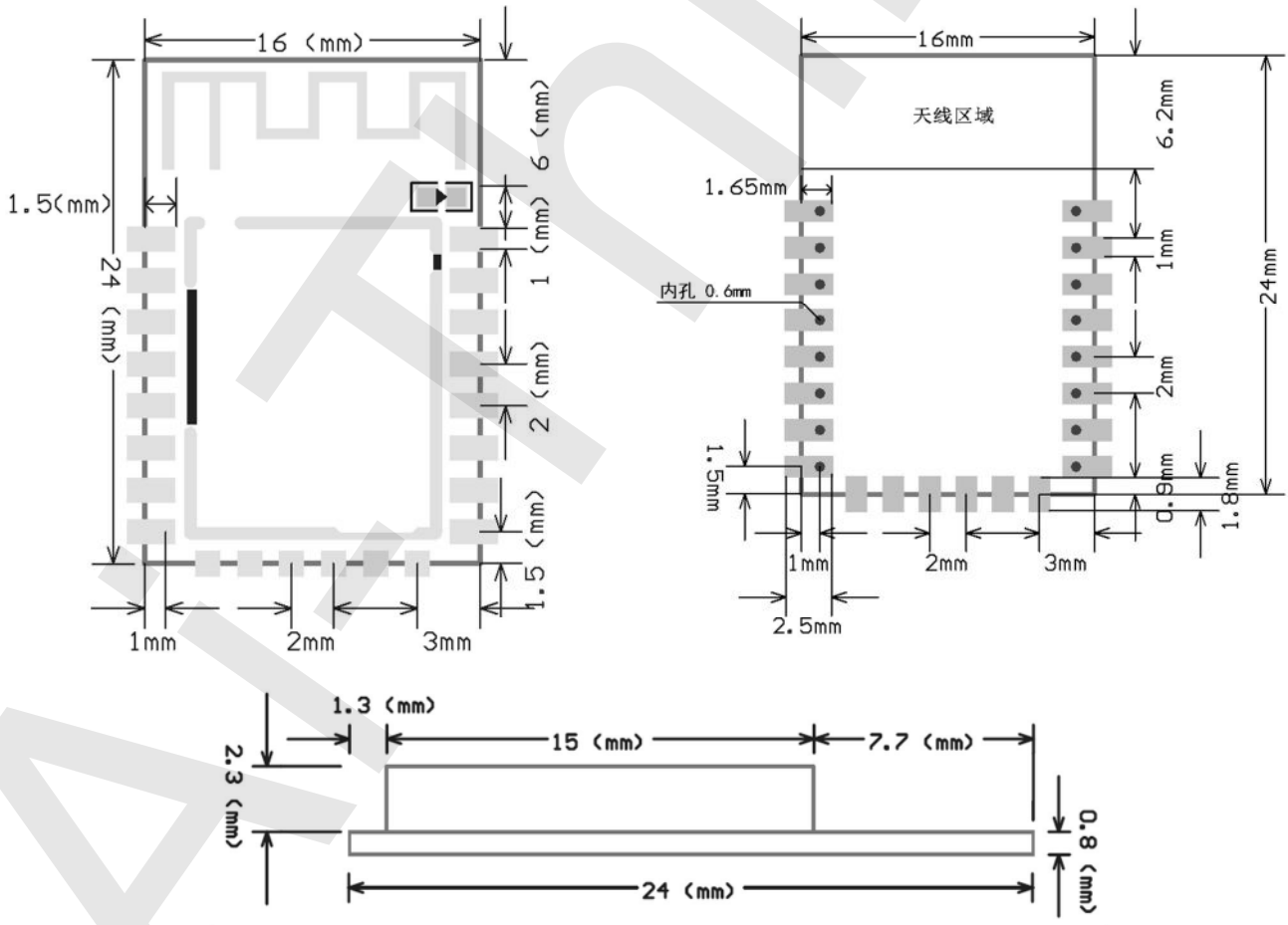
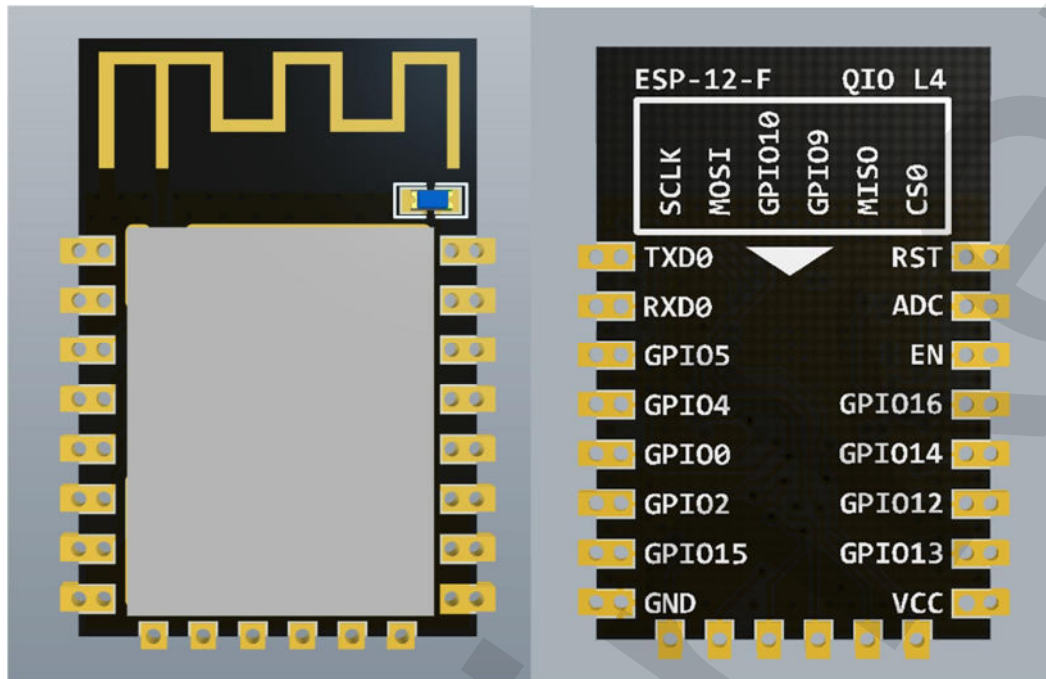

Features

- The smallest 802.11b/g/n Wi-Fi SOC module
- Low power 32-bit CPU, can also serve as the application processor
- Up to 160MHz clock speed
- Built-in 10 bit high precision ADC
- Supports UART/GPIO/IIC/PWM/ADC
- SMD-16 package for easy welding
- Integrated Wi-Fi MAC/BB/RF/PA/LNA
- Support multiple sleep patterns. Deep sleep current as low as 20uA
- UART baud rate up to 4Mbps
- Embedded LWIP protocol stack
- Supports STA/AP/STA + AP operation mode
- Support Smart Config/AirKiss technology
- Supports remote firmware upgrade (FOTA)
- General AT commands can be used quickly
- Support for the two development, integration of windows, Linux development environment

Product Specification

Table1.1 Product Specification Description

Module Model	ESP-12S
Package	SMD16
Size	24*16*3(± 0.2)mm
Certification	FCC/CE
SPI Flash	Default 32Mbit
Interface	UART/GPIO/ADC/PWM
IO Port	9
UART Baud rate	Support 300 ~ 4608000 bps , Default 115200 bps
Frequency Range	2412 ~ 2484MHz
Antenna	PCB Antenna
Transmit Power	802.11b: 16±2 dBm (@11Mbps) 802.11g: 14±2 dBm (@54Mbps) 802.11n: 13±2 dBm (@HT20, MCS7)
Receiving Sensitivity	CCK, 1 Mbps : -90dBm CCK, 11 Mbps: -85dBm 6 Mbps (1/2 BPSK): -88dBm 54 Mbps (3/4 64-QAM): -70dBm HT20, MCS7 (65 Mbps, 72.2 Mbps): -67dBm
Power (Typical Values)	Continuous Transmission=>Average: ~71mA, Peak: 500mA Modem Sleep: ~20mA Light Sleep: ~2mA Deep Sleep: ~0.02mA
Security	WEP/WPA-PSK/WPA2-PSK
Power Supply	Voltage 3.0V ~ 3.6V, Typical 3.3V, Current >500mA
Operating Temperature	-20 °C ~ 85 °C
Storage Environment	-40 °C ~ 85 °C , < 90%RH

2. Pin Definition

The ESP-12S module leads to 16 pins.

Figure 2.1 ESP-12S Pin diagram

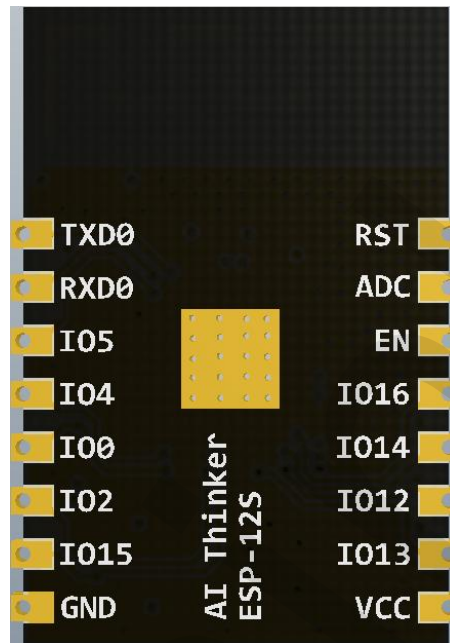

Table 2.2 Pin function description

No.	Pin Name	Functional Description
1	RST	Reset Pin, Active Low
2	ADC	AD conversion, Input voltage range 0~1V, the value range is 0~1024.
3	EN	Chip Enabled Pin, Active High
4	IO16	Connect with RST pin to wake up Deep Sleep
5	IO14	GPIO14; HSPI_CLK
6	IO12	GPIO12; HSPI_MISO
7	IO13	GPIO13; HSPI_MOSI; UART0_CTS

8	VCC	Module power supply pin, Voltage 3.0V ~ 3.6V
9	GND	GND
10	IO15	GPIO15; MTDO; HSPICs; UART0_RTS
11	IO2	GPIO2; UART1_TXD
12	IO0	GPIO0; HSPI_MISO; I2S1_DATA
13	IO4	GPIO4
14	IO5	GPIO5; IR_R
15	RXD	UART0_RXD; GPIO3
16	TXD	UART0_TXD; GPIO1

Table 2.3 Description of the ESP series module boot mode

Mode	CH_PD(EN)	RST	GPIO15	GPIO0	GPIO2	TXD0
Download mode	high	high	low	low	high	high
Running mode	high	high	low	high	high	high

Notes: Some of the pins inside the module have been pulled or pulled down, please refer to the schematic diagram.

3. Electrical Characteristics

Electrical Characteristics

Parameter	Symbol	Min	Typ	Max	Unit	
Storage temperature	-	-40	Normal	85	°C	
Operating temperature	-	-20	20	85	°C	
Maximum soldering temperature	IPC/JEDEC J-STD-020	-	-	260	°C	
Supply voltage	VDD	2.7	3.3	3.6	V	
I/O	V_{IL}/V_{IH}	-	-0.3/0.75VIO	-	0.25VIO/3.6	V
	V_{OL}/V_{OH}	-	N/0.8VIO	-	0.1VIO/N	V
	I_{MAX}	-	-	-	12	V

Wi-Fi Radio

Description	Min	Typ	Max	Unit
Input frequency	2400	-	2483.5	MHz
Input reflection	-	-	-10	dB
Output Power				
PA output power at 72.2 Mbps	15.5	16.5	17.5	dBm
PA output power in 11b mode	19.5	20.5	21.5	dBm
Sensitivity				
CCK, 1 Mbps		-90		dBm
CCK, 11 Mbps		-85		dBm
6 Mbps (1/2 BPSK)		-88		dBm
54 Mbps (3/4 64-QAM)		-70		dBm
HT20, MCS7 (65Mbps,72.2 Mbps)		-67		dBm
Adjacent channel rejection				
OFDM, 6 Mbps		37		dB
OFDM, 54 Mbps		21		dB
HT20, MCS0		37		dB
HT20, MCS7		20		dB

Power Consumption

The following power consumption data were obtained from the tests with a 3.3V power supply and a voltage stabilizer, in 25°C ambient temperature. All data are based on 50% duty cycle in continuous transmission mode.

Modes	Min	Typ	Max	Unit
Tx 802.11b, CCK 11Mbps, POUT=+17dBm	-	170	-	mA
Tx 802.11g, OFDM 54Mbps, POUT =+15dBm	-	140	-	mA
Tx 802.11n, MCS7, POUT =+13dBm	-	120	-	mA
Rx 802.11b, 1024 bytes packet length , -80 dBm	-	50	-	mA
Rx 802.11g, 1024 bytes packet length , -70 dBm	-	56	-	mA
Rx 802.11n, 1024 bytes packet length , -65 dBm	-	56	-	mA
Modem-sleep^①	-	20	-	mA
Light-sleep^②	-	2	-	mA
Deep-sleep^③	-	20	-	uA
Power Off	-	0.5	-	uA

Notes:

- **Modem-sleep** is used when such applications as PWM or I2S require the CPU to be working. In cases where Wi-Fi connectivity is maintained and data transmission is not required, the Wi-Fi Modem circuit can be shut down to save power, according to 802.11 standards (such as U-APSD). For example, in DTIM3, when ESP8266EX sleeps for 300 ms and wakes up for 3 ms to receive Beacon packages from AP, the overall average current consumption is about 20 mA.

- **Light-sleep** is used for applications whose CPU may be suspended, such as Wi-Fi switch. In cases where Wi-Fi connectivity is maintained and data transmission is not required, Wi-Fi Modem circuit and CPU can be shut down to save power, according to 802.11 standards (such as U-APSD). For example, in DTIM3, when ESP8266EX sleeps for 300 ms and wakes up for 3 ms to receive Beacon packages from AP, the overall average current consumption is about 2 mA.
- **Deep-sleep** is for applications that do not require Wi-Fi connectivity and only transmit data over long time lags, e.g., a temperature sensor that measures temperature every 100s. For example, when ESP8266EX sleeps for 300s then wakes up to connect to AP (taking about 0.3 ~ 1s), the overall average current consumption is far less than 1 mA. The current consumption of 20 μ A was obtained at the voltage of 2.5V.

4. Reflow Profile

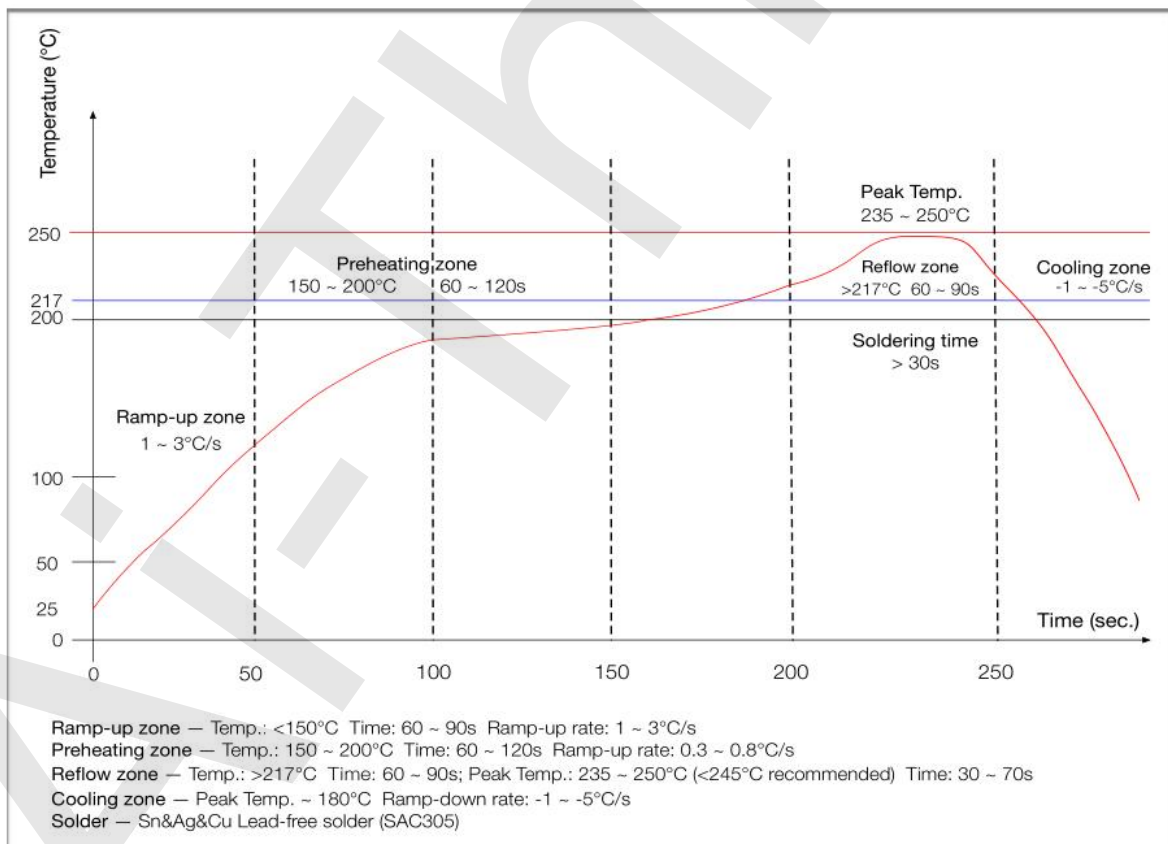

5. Application circuit

($\geq 500\text{mA}$, Recommend DC-DC or LDO independent power supply)

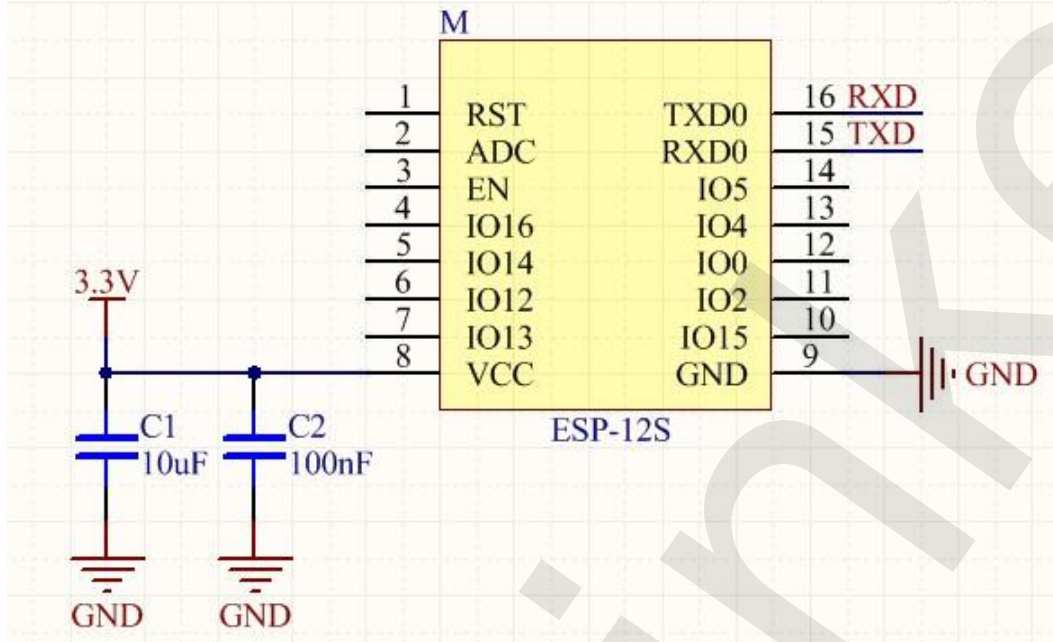

6. Schematics

