



# VC-02 Specification

Version V1.0.0

Copyright ©2022



## Content

1. Product overview.....	4
1.1. Characteristics.....	5
2. Main parameters.....	6
2.1. Static requirements .....	6
2.2. Electrical characteristics .....	7
2.3. Power consumption .....	7
3. Appearance size.....	8
4. Pin definition.....	9
5. Schematic diagram .....	11
6. Design guidance .....	12
6.1. Module application guide circuit .....	12
6.2. Power supply .....	12
6.3. GPIO level conversion.....	12
7. Reflow soldering graph .....	13
8. Product-related models.....	14
9. Product packaging information .....	15
10. Contact US.....	15
Disclaimer and copyright notice .....	16
Notice .....	16

## 1. Product overview

VC-02 is a low-cost pure offline speech recognition module developed by Shenzhen Ai-Thinker Technology Co., Ltd. The module uses the voice chip US516P6 launched by Unisound, and continuously optimizes and innovates algorithms in speech recognition technology. The offline recognition algorithm and chip architecture are deeply integrated to provide customers with ultra-low-cost offline speech recognition solutions. It can be widely and quickly applied to smart home, all kinds of smart small household appliances, 86 boxes, toys, lamps and other products that need voice control.

The US516P6 chip uses a 32-bit RISC architecture core and incorporates a DSP instruction set specifically for signal processing and speech recognition, an FPU arithmetic unit that supports floating-point operations, and an FFT accelerator.

VC-02 supports offline identification of 150 local instructions, RTOS lightweight system, rich peripheral interfaces, and simple and friendly custom tools.

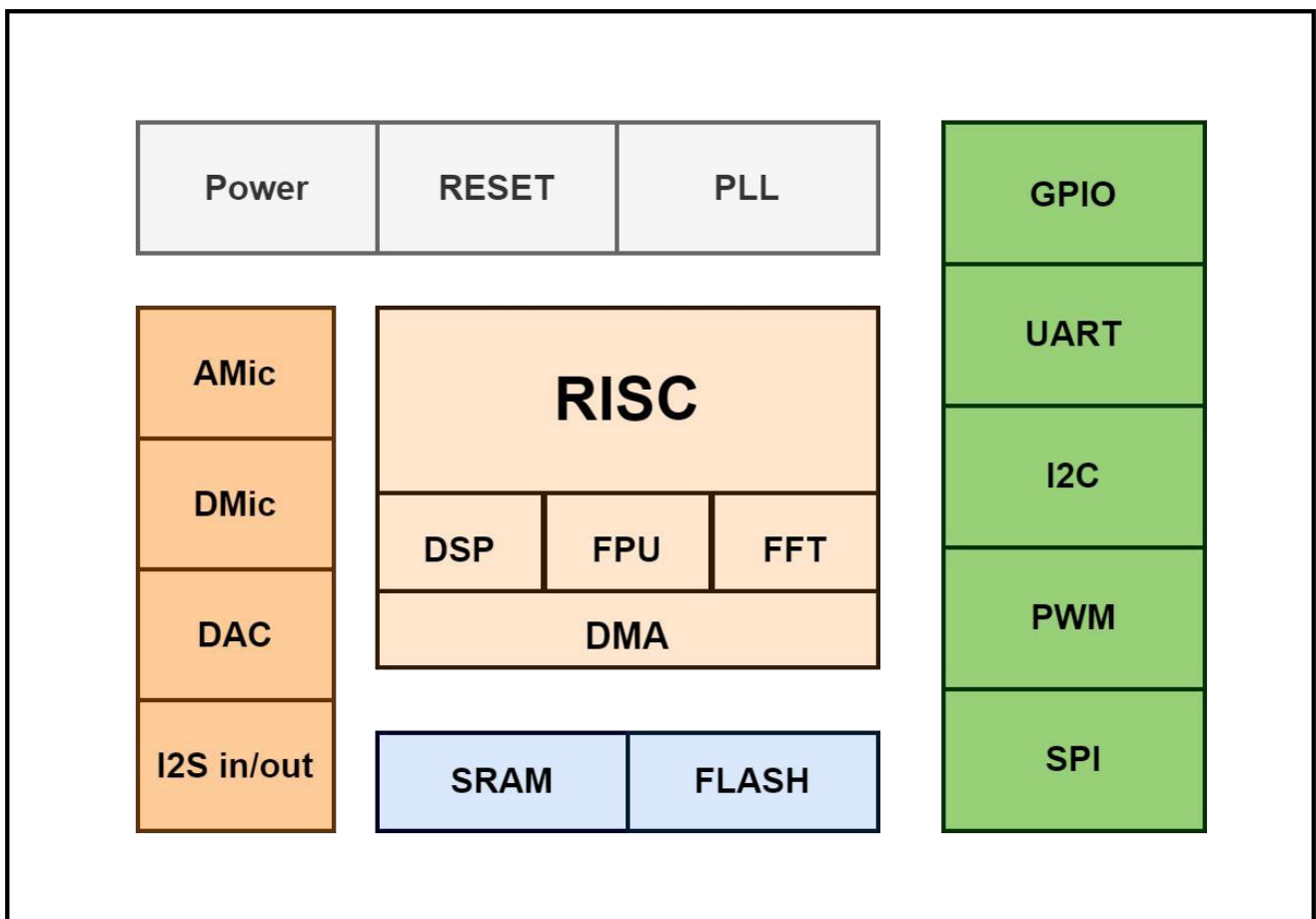

Figure 1 Main chip architecture diagram

## 1.1. Characteristics

### ■ Kernel

- ✓ 32bit RISC core, running at 240MHz
- ✓ Support DSP instruction set and FPU floating-point operation Unit
- ✓ FFT Accelerator: Support 1024-point complex FFT/IFFT operations, or 2048-point real FFT/IFFT operations
- ✓ Unisound customized speech algorithm operator

### ■ Storage

- ✓ Built-in 242KB high-speed SRAM
- ✓ Built-in 2MB FLASH

### ■ Audio input and output

- ✓ Supports 1 analog Mic input, SNR  $\geq$  94dB
- ✓ Support 4-channel digital Mic input
- ✓ Support dual-channel DAC output
- ✓ Supports I2S input/output

### ■ Power supply and clock

- ✓ Support 3.6 V-5V Range Power Input
- ✓ Built-in 5V to 3.3V, 3.3V to 1.2V LDO power the chip
- ✓ RC 12MHz clock source and PLL locked loop clock source
- ✓ Built-in POR(Power on Reset), low voltage detection and watchdog

### ■ Peripheral

- ✓ All GPIOs can be configured as external interrupt input and wake-up source
- ✓ 1 full-duplex UART with a maximum rate of 3Mbps.
- ✓ Support SPI, I2C, ADC, PWM interface

### ■ SDK

- ✓ Provides complete RTOS-based SDK
- ✓ Support fast and convenient UART, I2C and other control protocol development

## 2. Main parameters

**Table 1 Description of the main parameters**

<b>Model</b>	VC-02
<b>Package</b>	SMD-20
<b>Size</b>	18*17*3.2 ( $\pm 0.2$ ) mm
<b>Working temperature</b>	-40 °C ~ 85 °C
<b>Storage environment</b>	-40 °C ~ 125 °C, <90% RH
<b>Power supply</b>	Supply Voltage 3.6 V-5 V, Supply Current > 500mA
<b>Interfaces</b>	UART/I2C/PWM/SPI/GPIO
<b>IO</b>	10
<b>UART Rate</b>	Default 115200 bps
<b>SPI Flash</b>	2MB (built-in)

### 2.1. Static requirements

VC-02 module is an electrostatic sensitive device that requires special precautions during handling.



**Figure 2 ESD anti-static diagram**

## 2.2. Electrical characteristics

**Table 2 Electrical Characteristics Table**

Parameters	Conditions	Min. value	Typical value	Max. value	Unit
Supply voltage	VCC	3.6	-	5	V
Analog module power supply	AVDD	-	3.3	-	V
Built-in LDO digital module power supply	LDO33DO	-	3.3	-	V
Core operating voltage	LDO12O	-	1.2	-	V
IO	US_SPK_MUTE	-0.047	-	3.3	V

## 2.3. Power consumption

The following power consumption data are measured based on a 5V power supply and an ambient temperature of 25°C.

- In the configuration of the speaker and microphone under the measured active state VC-02 power consumption.

**Table 3 Power consumption table**

Mode	Min. value	Average	Max. value	Unit
Active (response broadcast), the command word "turn on the air	56.1	115.1	232	mA
Standby status	55.7	56.1	56.6	mA
Hibernation state	0.6	-	0.7	mA

### 3. Appearance size

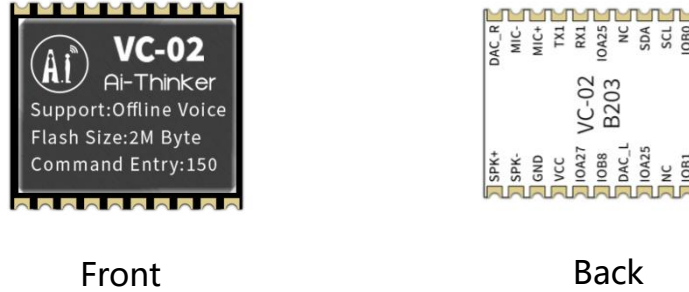

Figure 3 Module appearance diagram (For reference only)

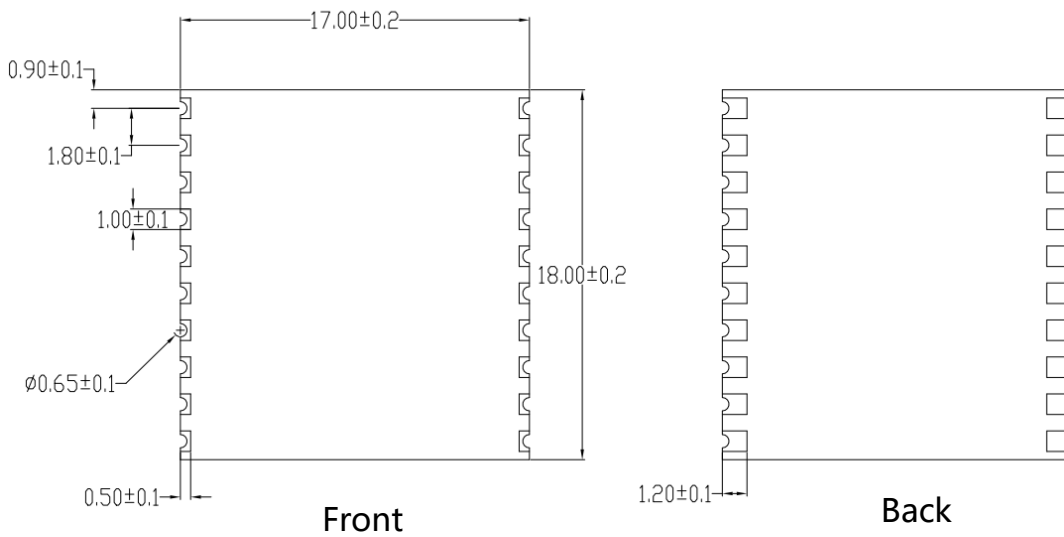
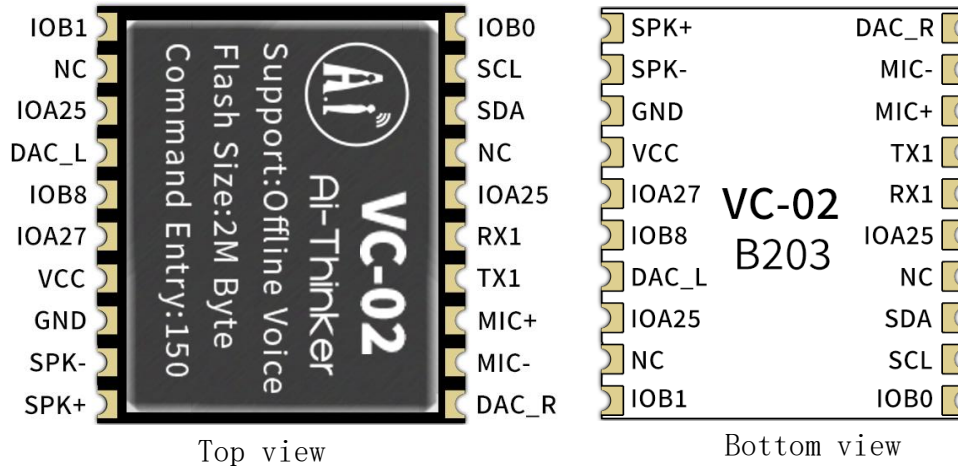

Figure 4 Module Size

## 4. Pin definition

The VC-02 module has a total of 20 pins, As shown in below pin diagram, the pin function definition table is the interface definition.



**Figure 5 Module pin diagram**

**Table 4 Pin function definition table**

Foot sequence	Name	Function description
1	DAC_R	Reserved R-channel audio output. This function is not currently supported.
2	MIC-	MIC-Input
3	MIC +	MIC + input
4	TX1	GPIO_B6/UART1_TXD,3.3V level
5	RX1	GPIO_B7/UART1_RXD,3.3V level
6	IOA25	IO/ADC4/SPI_MISO
7	NC	Hanging
8	SDA	GPIO_B3/I2C_SDA/TIM4_PWM,3.3V level
9	SCL	GPIO_B2/I2C_SCL/TIM3_PWM,3.3V level
10	IOB0	IO/UART1_TXD/I2C_SCL/TIM3_PWM
11	IOB1	IO/UART1_RXD/I2C_SDA/TIM4_PWM
12	NC	Hanging
13	IOA26	IO/ADC5/SPI_CLK
14	DAC_L	Reserved audio L-channel output. This function is not currently supported.
15	IOB8	IO/Virtual Software UART-TX(Log Output Pin)
16	IOA27	IO/US_SPIM_MOSI
17	VCC	3.6-5V power input
18	GND	GND ground
19	SPK-	SPK-8 $\Omega$ 2W
20	SPK +	SPK +8 $\Omega$ 2W

## 5. Schematic diagram

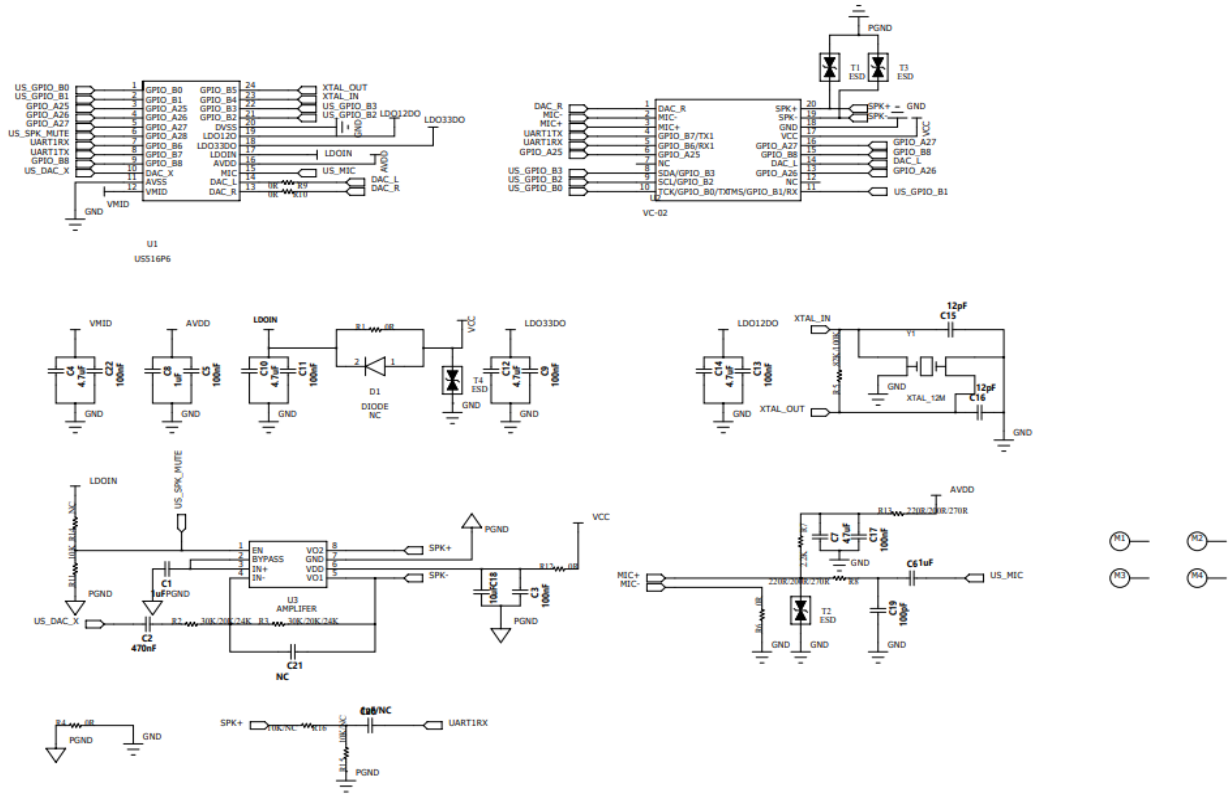

Figure 6 Module schematic diagram

## 6. Design guidance

### 6.1. Module application guide circuit

(>= 500mA, it is recommended to use DC-DC or LDO for independent power supply)

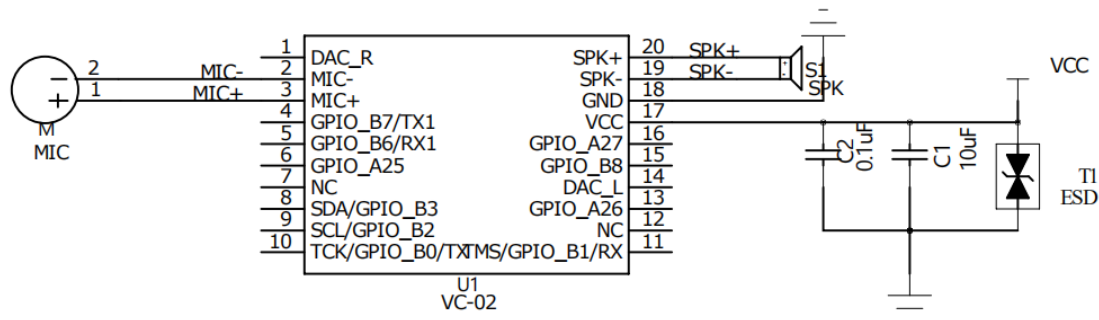

Figure 7 Application circuit diagram

### 6.2. Power supply

- Recommended 3.6-5V voltage, peak current above 500mA.
- It is recommended to use LDO for power supply; if you use DC-DC, it is recommended to control the ripple within 50mV.
- The DC-DC power supply circuit suggests that the position of the dynamic response capacitor can be optimized when the load changes greatly.

### 6.3. GPIO level conversion

- Some IO ports are drawn out from the periphery of the module. If you need to use it, it is recommended to connect a 10-100 ohm resistor in series on the IO port. This can suppress overshoot and make the level on both sides more stable. It helps both EMI and ESD.
- For the special IO port to be pulled up and down, refer to the instructions in the specification, which will affect the startup configuration of the module.
- The IO port of the module is 3.3V. If the master control does not match the IO port level of the module, a level conversion circuit needs to be added.
- If the IO port is directly connected to the peripheral interface, or the terminal such as the pin, it is recommended to reserve the ESD device near the terminal.

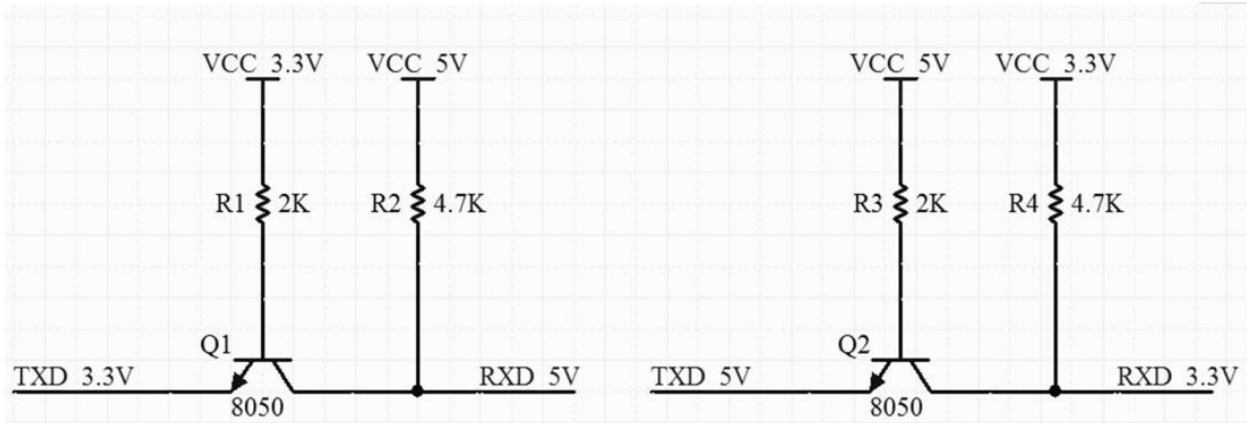

Figure 8 Level Conversion Circuit

## 7. Reflow soldering graph

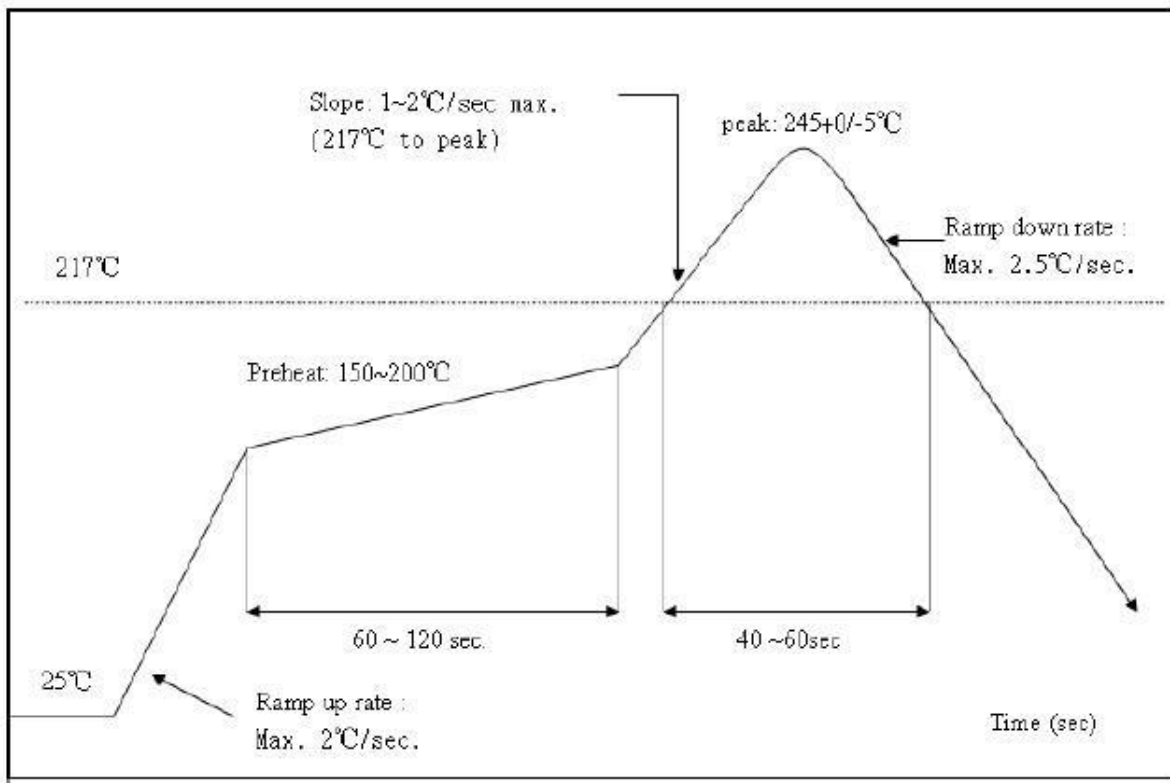

Figure 9 Reflux Soldering Curve

## 8. Product-related models

**Table 5 Product-related model table**

Product model	Power supply	Package	Size	Interface
VC-01 module	3.6-5 V, I>500mA	SMD-24	25.5*24*3.2 (± 0. 2) mm	UART
VC-02 module	3.6-5 V, I>500mA	SMD-20	18*17*3.2 (± 0. 2) mm	UART
VC-02-Kit Development Board	3.6-5 V, I>500mA	DIP-20	42*36 (± 0. 2) mm	UART
VC-01-Kit Development Board	3.6-5 V, I>500mA	DIP-20	42*36 (± 0. 2) mm	UART
Product related information: <a href="https://docs.ai-thinker.com">https://docs.ai-thinker.com</a>				