



Ai-WB2-12F-Kit Specification

Version V1.0.0

Copyright ©2022

Content

1. Product Overview.....	4
1.1. Characteristic.....	5
2. Main parameters.....	6
2.1. Power supply selection.....	6
2.2. Static electricity requirements.....	6
2.3. Electrical characteristics.....	7
2.4. Wi-Fi RF performance	7
2.5. BLE RF performance	8
2.6. Power.....	8
3. Appearance size.....	9
4. Indicator light and button description	10
5. Pin definition.....	11
6. Schematic diagram	13
7. Product Related models.....	14
8. Product package information	15
9. Contact us.....	15
Disclaimer and copyright notice	16
Notice	16

1. Product Overview

Ai-WB2-12F-Kit is a development board designed for Ai-WB2-12F modules. Ai-WB2-12F is a Wi-Fi & Bluetooth module developed by Shenzhen Ai-Thinker Technology Co., Ltd. The module is equipped with BL602 chip as the core processor and supports Wi-Fi 802.11b/g/n protocol and BLE 5.0 protocol. The BL602 chip has a built-in 32-bit RISC CPU with low power consumption, 276KB RAM, and a wide range of peripheral interfaces, including SDIO, SPI, UART, VDC, IR remote, PWM, ADC, DAC, PIR, and GPIO. It can be widely used in Internet of Things (IoT), mobile devices, wearable electronic devices, smart home and other fields.

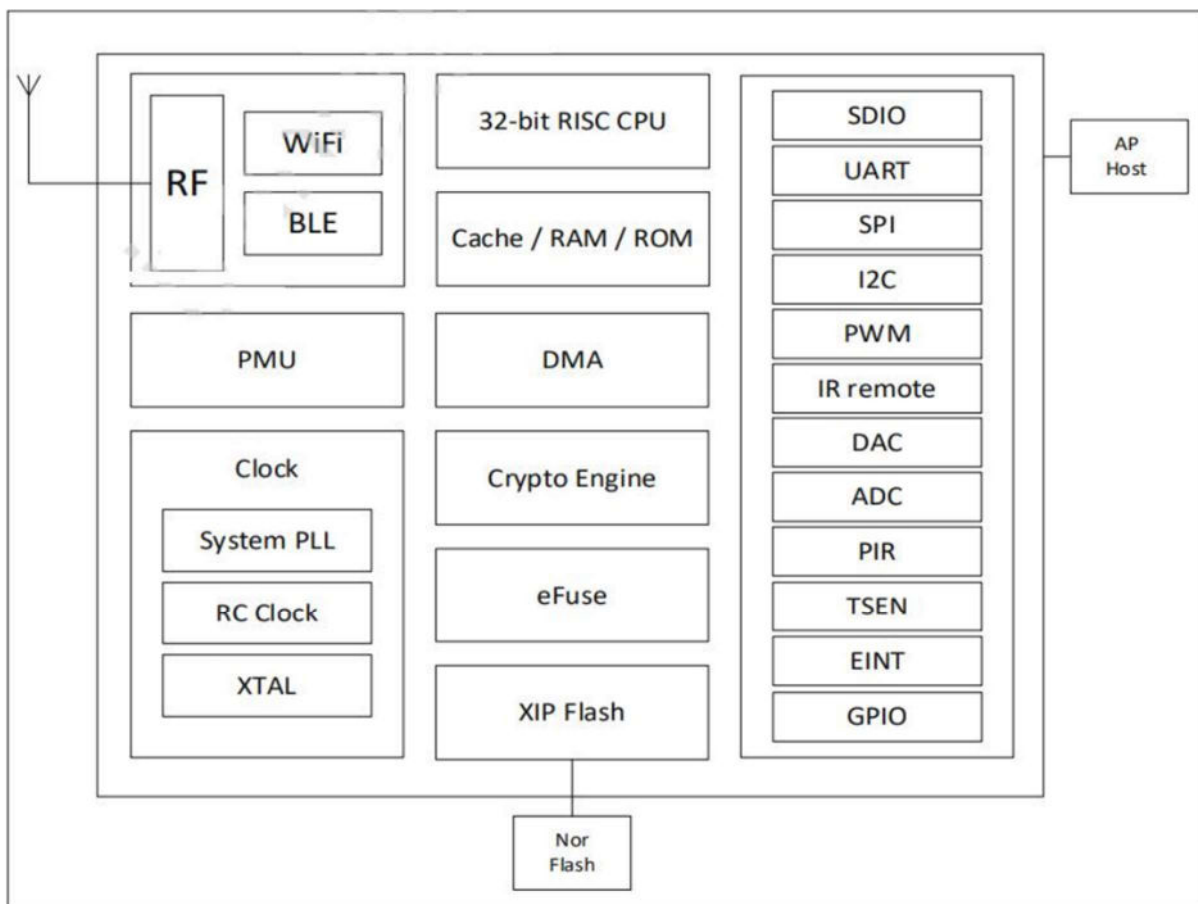

Figure 1 Main chip architecture diagram

1.1. Characteristic

- DIP-30 package
- Supports IEEE 802.11 B/g/n protocol
- Wi-Fi security supports WPS/WEP/WPA/WPA2 Personal/WPA2 Enterprise/WPA3
- Supports 20MHz bandwidth with a maximum speed of 72.2 Mbps
- Bluetooth BLE 5.0, Bluetooth Mesh
- Supports Station + BLE mode, Station + SoftAP + BLE mode
- Supports 32-bit RISC CPU and 276KB RAM
- Secure Startup. Images with ECC-256 signatures are supported
- Supports real-time AES decryption (OTFAD) in QSPI and SPI Flash, and supports AES 128 CTR mode
- Supports AES 128, 192, and 256-bit encryption engines
- Supports SHA-1/224/256
- Real random number generator (TRNG)
- The public key accelerator (PKA) supports large numbers of basic operations. The software provides application interfaces such as signature and verification
- Supports SDIO, SPI, UART, VDC, IR remote, PWM, ADC, DAC, PIR, and GPIO
- Integrated Wi-Fi MAC/BB/RF/PA/LNA/Bluetooth
- Supports multiple sleep modes with a deep sleep current of 12 μ A
- Quick Start of universal AT commands
- Supports secondary development and integrates Windows and Linux development environments

2. Main parameters

Table 1 main parameters

Model	Ai-WB2-12F-Kit
Package	DIP-30
Size	49.66*25.40(±0.2)mm
Antenna	On-Board PCB antenna
Frequency	2400 ~ 2483.5MHz
Operation temperature	-40°C ~ 85°C
Storage environment	-40°C ~ 125°C, < 90%RH
Power supply	Support voltage 3.3V or 5V, power supply current≥500mA
Interfaces	UART/GPIO/ADC/PWM/I2C/SPI
I/O	11
UART rate	Default value: 115200 bps
Bluetooth	BLE 5.0
Security	WPS/WEP/WPA/WPA2 Personal/WPA2 Enterprise/WPA3
Flash	Default: 4MByte

2.1. Power supply selection

Ai-WB2-12F-Kit supports three power supply modes:

- Type-C interface power supply (recommended)
- 5V and GND pin power supply
- 3V3 and GND pin power supply

2.2. Static electricity requirements

Ai-WB2-12F-Kit is an electrostatic sensitive equipment, special precautions should be taken during handling.



Figure 2 ESD anti-static diagram

2.3. Electrical characteristics

Table 2 Electrical Characteristics Table

Parameter		Conditio	Min.	Typical value	Max.	Unit
Interface Power supply (Type-C)		VDD	4.5	5	5.3	V
Power supply voltage (pin)		VDD	2.7	3.3	3.6	V
I/O	VIL	-	-	-	0.3*VDDIO	V
	VIH	-	0.7*VDDIO	-	-	V
	VOL	-	-	0.1*VDDIO	-	V
	VOH	-	-	0.9*VDDIO	-	V
	IMAX	-	-	-	15	mA

2.4. Wi-Fi RF performance

Table 3 Wi-Fi RF performance table

Description	Typical value			Unit
Spectrum Range	2400 - 2483.5			MHz
Output power				
Model	Min.	Typical value	Max.	Unit
11n mode HT20, PA output power	-	16	-	dBm
In 11G mode, PA output power	-	17	-	dBm
In 11b mode, PA output power	-	19	-	dBm
Receiving sensitivity				
Model	Min.	Typical value	Max.	Unit
11b,1 Mbps	-	-98	-	dBm
11b,11 Mbps	-	-90	-	dBm
11g, 6 Mbps	-	-93	-	dBm
11g,54 Mbps	-	-76	-	dBm
11n, HT20 (MCS7)	-	-73	-	dBm

2.5. BLE RF performance

Table 4 BLE RF performance table

Description	Typical value			Unit
Spectrum Range	2400 - 2483.5			MHz
Output power				
Rate Mode	Min.	Typical value	Max.	Unit
1Mbps	-	9	15	dBm
Receiving sensitivity				
Rate Mode	Min.	Typical value	Max.	Unit
1Mbps sensitivity @ 30.8% PER	-	-96	-	dBm

2.6. Power

The following power consumption data is based on a 3.3V power supply, an ambient temperature of 25°C, and measured using an internal regulator.

- All measurements are completed at the antenna interface with a filter.
- All emission data are measured in a continuous emission mode based on a 100% duty cycle.

Table 5 Power Consumption Table

Model	Min.	AVG	Max.	Unit
Tx 802.11b, 11Mbps, POUT = + 21dBm	-	260	-	mA
Tx 802.11g, 54Mbps, POUT = + 18dBm	-	245	-	mA
Tx 802.11n, MCS7, POUT = + 17dBm	-	230	-	mA
Rx 802.11b, 1024 bytes long	-	65	-	mA
Rx 802.11g, 1024 bytes long	-	65	-	mA
Rx 802.11n, 1024 bytes long	-	65	-	mA
Deep-Sleep	-	12	-	μA

3. Appearance size

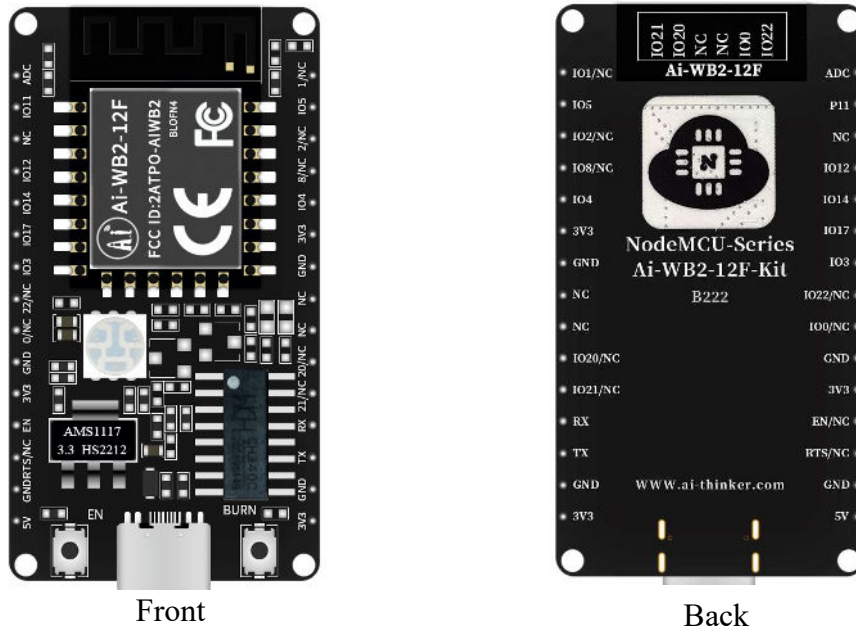

Figure 3 External view (For reference only)

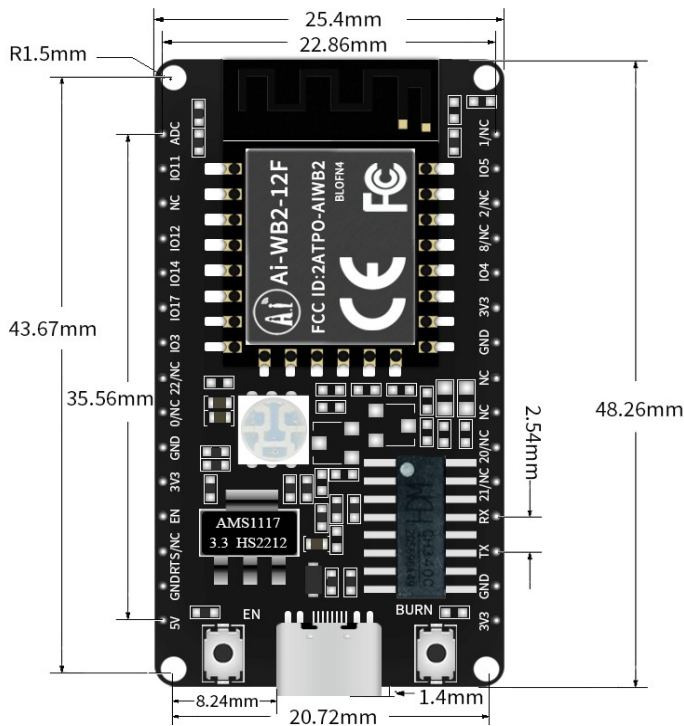

Figure 4 size chart

4. Indicator light and button description

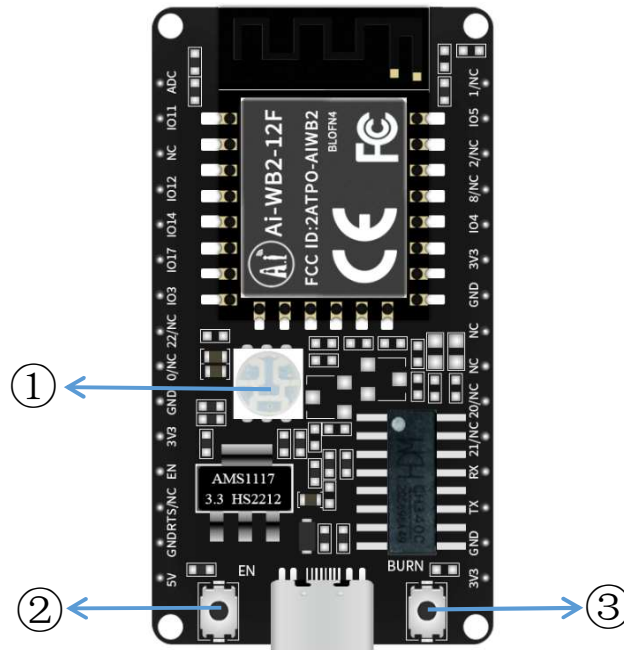

Figure 5 Ai-WB2-12F-Kit indicator light and key position

Table 6 Ai-WB2-12F-Kit indicator light and key position

①	RGB light (red light is connected to IO14, Green Light is connected to IO17, blue light is connected to IO3, high level effective)
②	Reset button
③	To burn the button, you need to press the Burn button and then press the reset button.

2	IO11	GPIO11/SPI_SCLK/IIC_SDA/ADC_CH10
3	NC	Empty feet
4	IO12	GPIO12/SPI_MOSI/MISO/IIC_SCL/PWM_CH2/ADC_CH0
5	IO14	GPIO14/SPI_SS/IIC_SCL/PWM_CH4/ADC_CH2
6	IO17	GPIO17/SPI_MOSI/MISO/IIC_SDA/PWM_CH2
7	IO3	GPIO3/SPI_SCLK/IIC_SDA/PWM_CH3
8	IO22/NC	The default NC is unavailable
9	IO0/NC	The default NC is unavailable
10	GND	Ground
11	3V3	3.3V power supply
12	EN	By default, it is enabled as a chip. The high level is effective and cannot be used together with RST
13	RST/NC	By default, it is suspended and can be customized as a reset pin. It is valid at a low level. If you need to use it, please contact Ai-Thinker
14	GND	Conductive earth
15	5V	5V power supply
16	3V3	3.3V power supply
17	GND	Ground
18	TX	TXD/GPIO16/SPI_MOSI/MISO/IIC_SCL/PWM_CH1
19	RX	RXD/GPIO7/SPI_SCLK/IIC_SDA/PWM_CH2
20	IO21/NC	The default NC is unavailable
21	IO20/NC	The default NC is unavailable
22	NC	Empty feet
23	NC	Empty feet
24	GND	Ground
25	3V3	3.3V power supply
26	IO4	GPIO4/SPI_MOSI/MISO/IIC_SCL/PWM_CH4/ADC_CH4
27	IO8/NC	The default NC is unavailable
28	IO2/NC	It is not recommended and is shared with the internal Flash of the module If you need to use it, please contact Ai-Thinker GPIO2/SPI_SS/IIC_SCL/PWM_CH2
29	IO5	GPIO5/SPI_MOSI/MISO/IIC_SDA/PWM_CH0/ADC_CH4
30	IO1/NC	It is not recommended and is shared with the internal Flash of the module If you need to use it, please contact Ai-Thinker AGPIO1/SPI_MOSI/MISO/IIC_SDA/PWM_CH1

6. Schematic diagram

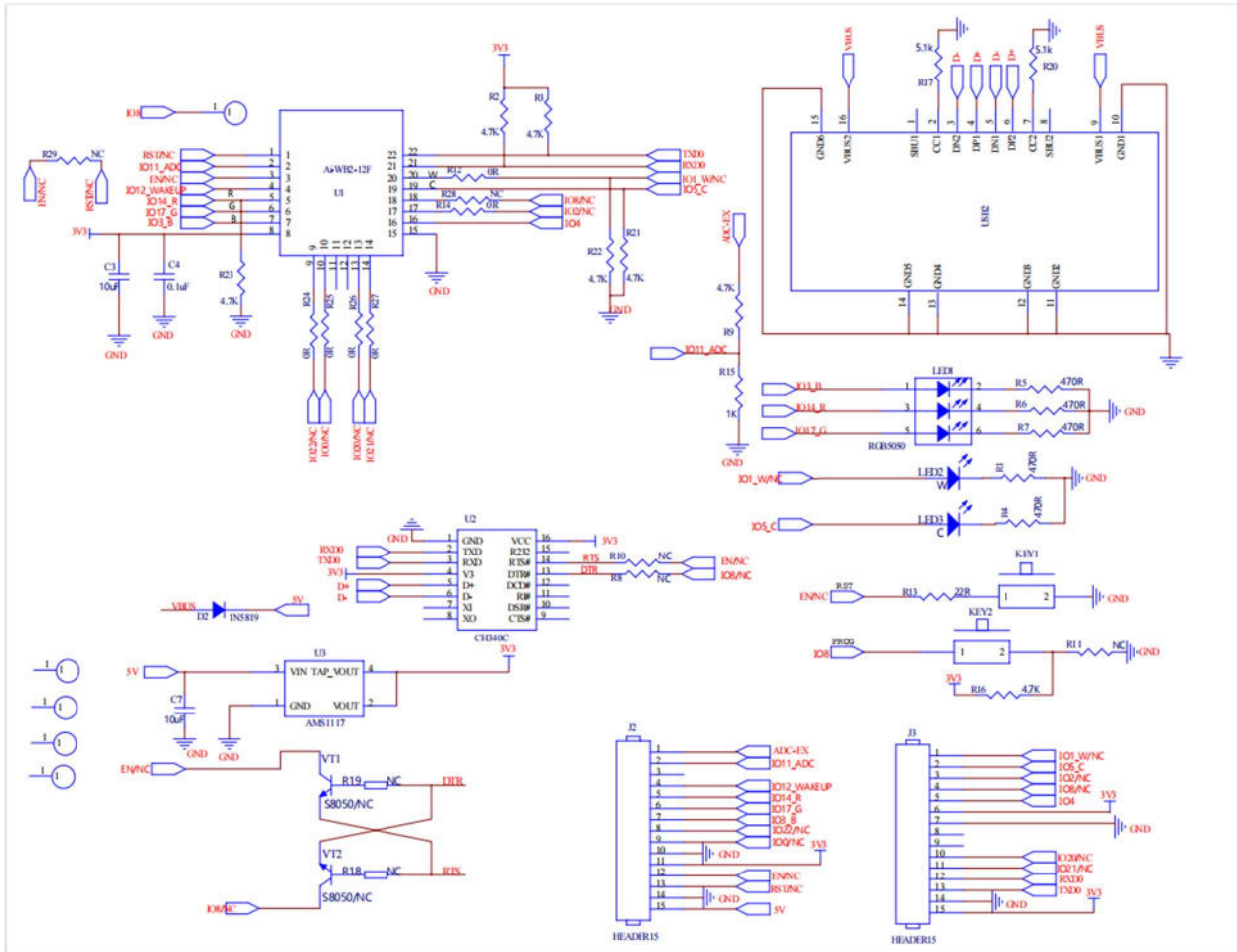

Figure 6 schematic diagram

7. Product Related models

Table 8 product related model table

Model	Power supply	Package	Size	Antenna
Ai-WB2-12S	2.7V ~ 3.6V, I _≥ 500mA	SMD-16	24.0*16.0*3.1(±0.2)mm	On-board PCB antenna
Ai-WB2-12F	2.7V ~ 3.6V, I _≥ 500mA	SMD-22	24.0*16.0*3.1(±0.2)mm	On-board PCB antenna
Ai-WB2-07S	2.7V ~ 3.6V, I _≥ 500mA	SMD-22	17.0*16.0*3.1(±0.2)mm	IPEX
Ai-WB2-13	2.7V ~ 3.6V, I _≥ 500mA	SMD-18	20.0*18.0*3.1(±0.2)mm	On-board PCB antenna
Ai-WB2-13U	2.7V ~ 3.6V, I _≥ 500mA	SMD-18	14.0*18.0*3.1(±0.2)mm	IPEX
Ai-WB2-32S	2.7V ~ 3.6V, I _≥ 500mA	SMD-38	25.5*18.0*3.1(±0.2)mm	Default On-board PCB antenna/compatible with IPEX
Ai-WB2-01M	2.7V ~ 3.6V, I _≥ 500mA	DIP-18	18.0*18.0*2.8(±0.2)mm	On-board PCB antenna
Ai-WB2-12F-Kit	3.3V or 5V, I _{>} 500mA	DIP-30	49.66*25.4(±0.2)mm	On-board PCB antenna
Ai-WB2-13-Kit	3.3V or 5V, I _{>} 500mA	DIP-30	49.66*25.4(±0.2)mm	On-board PCB antenna
Ai-WB2-32S-Kit	3.3V or 5V, I _{>} 500mA	DIP-38	55.05*25.4(±0.2)mm	On-board PCB antenna
Product information: https://docs.ai-thinker.com				

Disclaimer and copyright notice

The information in this article, including the URL address for reference, is subject to change without notice.

The document is provided "as is" without any guarantee responsibility, including any guarantee for merchantability, suitability for a specific purpose, or non-infringement, and any guarantee mentioned elsewhere in any proposal, specification or sample. This document does not bear any responsibility, including the responsibility for infringement of any patent rights arising from the use of the information in this document. This document does not grant any license for the use of intellectual property rights in estoppel or other ways, whether express or implied.

The test data obtained in the article are all obtained from Ai-Thinker's laboratory tests, and the actual results may vary slightly.

All brand names, trademarks and registered trademarks mentioned in this article are the property of their respective owners, and it is hereby declared.

The final interpretation right belongs to Shenzhen Ai-Thinker Technology Co., Ltd.

Notice

Due to product version upgrades or other reasons, the contents of this manual may be changed.

Shenzhen Ai-Thinker Technology Co., Ltd. reserves the right to modify the contents of this manual without any notice or prompt.

This manual is only used as a guide. Shenzhen Ai-Thinker Technology Co., Ltd. makes every effort to provide accurate information in this manual. However, Shenzhen Ai-Thinker Technology Co., Ltd. does not guarantee that the contents of the manual are completely free of errors. All statements and information in this manual. And the suggestion does not constitute any express or implied guarantee.