



Ai-WB2-01S Specification

Version V1.0.1

Copyright ©2022

Content

1. Product Overview	4
1.1. Characteristic	5
2. Main parameters	6
2.1. Static electricity requirement	6
2.2. Electrical characteristics	7
2.3. Wi-Fi RF performance	7
2.4. BLE RF performance	8
2.5. Power	8
3. Appearance size	9
4. Pin definition	10
5. Schematic	12
6. Antenna parameters	13
6.1. Antenna Test prototype	13
6.2. Antenna S parameters	14
6.3. Antenna gain and efficiency	14
6.4. Antenna pattern	15
6.5. RF OTA parameters	16
7. Design Guidance	17
7.1. Application Guide circuit	17
7.2. Recommend PCB package size	17
7.3. Antenna layout requirements	18
7.4. Power supply	19
7.5. GPIO	20
8. Storage Conditions	21
9. Reflow welding curve diagram	21
10. Product packaging information	22
11. Contact us	22
Disclaimer and copyright notice	23
Notice	23

1. Product Overview

Ai-WB2-01S is a Wi-Fi & BLE module developed by Shenzhen Ai-Thinker Technology Co., Ltd. This module is equipped with BL602 chip as the core processor and supports Wi-Fi 802.11b/g/n protocol and BLE 5.0 protocol. The BL602 chip has a built-in 32-bit RISC CPU with low power consumption and 276KB RAM. It can be widely used in Internet of Things (IoT), mobile devices, wearable electronic devices, smart home and other fields.

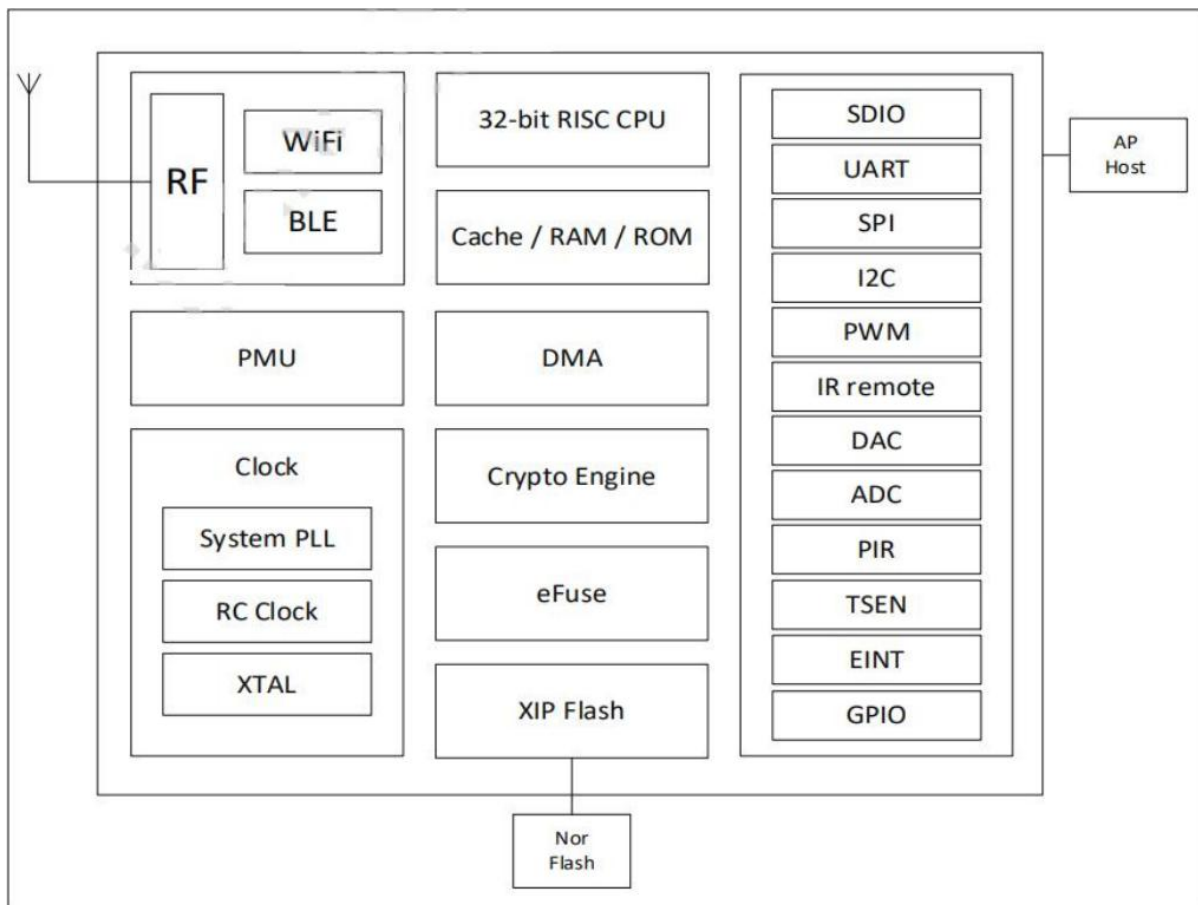

Figure 1 architecture of main chip

1.1. Characteristic

- DIP-8 package
- Supports IEEE 802.11 B/g/n protocol
- Wi-Fi security supports WPS/WEP/WPA/WPA2 Personal/WPA2 Enterprise/WPA3
- Supports 20MHz bandwidth with a maximum speed of 72.2 Mbps.
- Bluetooth 5.0, Bluetooth Mesh
- Supports Station + BLE mode, Station + SoftAP + BLE mode
- Supports 32-bit RISC CPU and 276KB RAM
- Secure Startup, supports Images with ECC-256 signatures
- Supports real-time AES decryption (OTFAD) in QSPI and SPI Flash, and supports AES 128 CTR mode
- Supports AES 128, 192, and 256-bit encryption engines
- Supports SHA-1/224/256
- Support True Random Number Generator (TRNG)
- Public Key Accelerator (PKA), support large number basic operations, software provides signature, verification and other application program interface
- Supports UART,PWM,ADC, and GPIO
- Integrated Wi-Fi MAC/BB/RF/PA/LNA/BT
- Supports multiple sleep modes with a deep sleep current of 12 μ A
- Universal AT instruction for quick start
- Supports secondary development and integrates Windows and Linux development environments

2. Main parameters

Table 1 main parameters

Model	Ai-WB2-01S
Package	DIP-8
Size	14.5*24.5*11.2(±0.2)mm
Antenna	on-board PCB antenna
Frequency	2400 ~ 2483.5MHz
Operating temperature	-40°C ~ 85°C
Storage temperature	-40°C ~ 125°C, < 90%RH
Power supply	Power supply voltage 2.7V ~ 3.6V, power supply current ≥500mA
Interface	UART/GPIO/ADC/PWM
IO	3
UART rate	Default value: 115200 bps
Security	WPS/WEP/WPA/WPA2 Personal/WPA2 Enterprise/WPA3
Flash	Default 2MByte Support expansion

2.1. Static electricity requirement

Ai-WB2-01S are electrostatic sensitive equipment, special precautions should be taken during handling.



Figure 2 ESD anti-static diagram

2.2. Electrical characteristics

Table 2 Electrical Characteristics Table

Parameter	Conditio	Minimum	Typical value	Maximum	Com
Supply voltage	VDD	2.7	3.3	3.6	V
I/O	VIL	-	-	0.3*VDDIO	V
	VIH	-	0.7*VDDIO	-	V
	VOL	-	-	0.1*VDDIO	V
	VOH	-	-	0.9*VDDIO	V
	IMAX	-	-	-	15

2.3. Wi-Fi RF performance

Table 3 Wi-Fi RF performance table

Description	Typical value			Unit
Frequency range	2400 ~ 2483.5MHz			MHz
Output power				
Mode	Min.	Typical value	Max.	Unit
11n mode HT20, PA output power	-	16	-	dBm
11g mode, PA output power	-	17	-	dBm
11b mode, PA output power	-	19	-	dBm
Receiving sensitivity				
Mode	Min.	Typical value	Max.	Unit
11b, 1 Mbps	-	-98	-	dBm
11b, 11 Mbps	-	-90	-	dBm
11g, 6 Mbps	-	-93	-	dBm
11g, 54 Mbps	-	-76	-	dBm
11n, HT20 (MCS7)	-	-73	-	dBm

2.4. BLE RF performance

Table 4 BLE RF performance table

Description	Typical value			Unit
Frequency range	2400 ~ 2483.5MHz			MHz
Output power				
Rate Mode	Min.	Typical value	Max.	Unit
1Mbps	-	9	15	dBm
Receiving sensitivity				
Rate Mode	Min.	Typical value	Max.	Unit
1Mbps sensitivity @ 30.8% PER	-	-96	-	dBm

2.5. Power

The following power consumption data is based on a 3.3V power supply, 25°C ambient temperature, and measured using an internal regulator

- All measurements are made at the antenna interface with a filter.
- All transmission data are based on 100% duty cycle in continuous transmission mode

Table 5 Power Consumption Table

Mode	Min.	Average	Max.	Comp
Tx 802.11b, 11Mbps, POUT=+21dBm	-	320	-	mA
Tx 802.11g, 54Mbps, POUT=+18dBm	-	269	-	mA
Tx 802.11n, MCS7, POUT=+16dBm	-	240	-	mA
Rx 802.11b, packet length 1024 byte	-	63	-	mA
Rx 802.11g, packet length 1024 byte	-	63	-	mA
Rx 802.11n, Packet length 1024 byte	-	63	-	mA
Deep-Sleep	-	12	-	μA

3. Appearance size

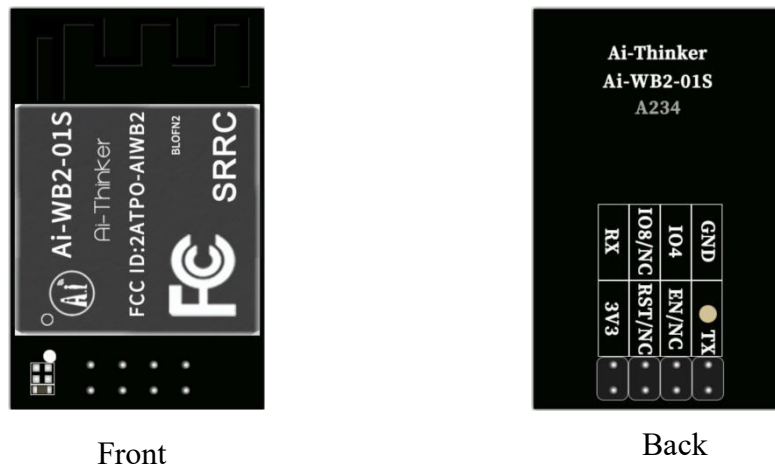

Figure 3 External view (for reference only)

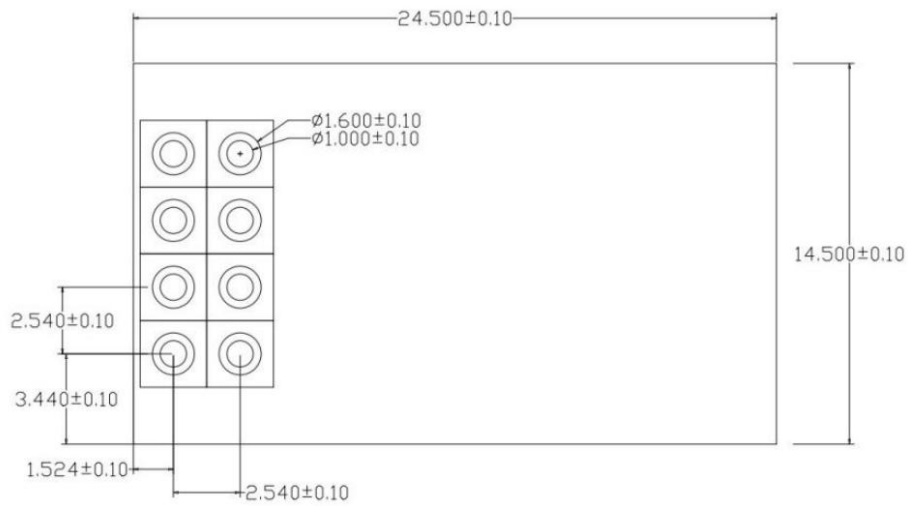

Figure 4 Dimension diagram (unit: mm)

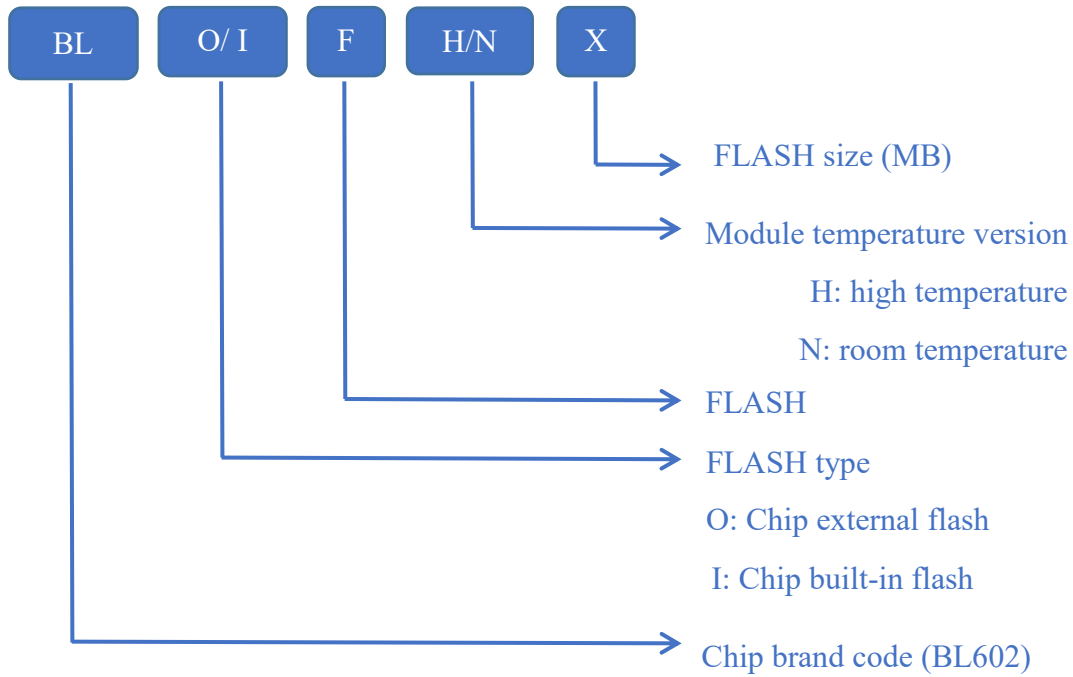
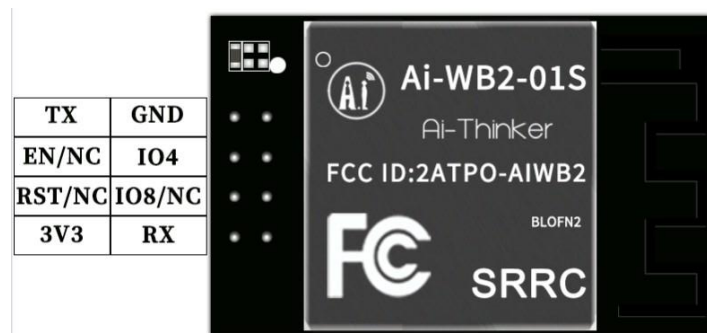

Figure 5 the representative information of screen printing of Shield

4. Pin definition

Ai-WB2-01S module is connected with a total of 8 pins, as shown in the pin schematic diagram, pin function definition table is the interface definition.



Front

Figure 6 pin diagram

Table 6 Definition table of pin functions

No.	Name	Description
1	GND	Ground
2	IO4	GPIO4/SPI MOSI/MISO/IIC SCL/PWM CH4/ADC CH4
3	IO8/NC	NC, unavailable. If you need to use it, please contact Ai-Thinker. Bootstrap/GPIO8/SPI_MOSI/MISO/IIC_SCL/PWM_CH3
4	RX	RXD/GPIO7/SPI_SCLK/IIC_SDA/PWM_CH2
5	TX	TXD/GPIO16/SPI_MOSI/MISO/IIC_SCL/PWM_CH1
6	EN/NC	By default, it is enabled as a chip and is effective at a high level
7	RST/NC	The default NC is unavailable
8	3V3	3.3V power supply. It is recommended that the output current of the external power supply be higher than 500mA
Note: 1. At the moment of power-on, if Bootstrap GPIO8 is high, the module enters the programming mode; if Bootstrap GPIO8 is low, the module starts normally.		

5. Schematic

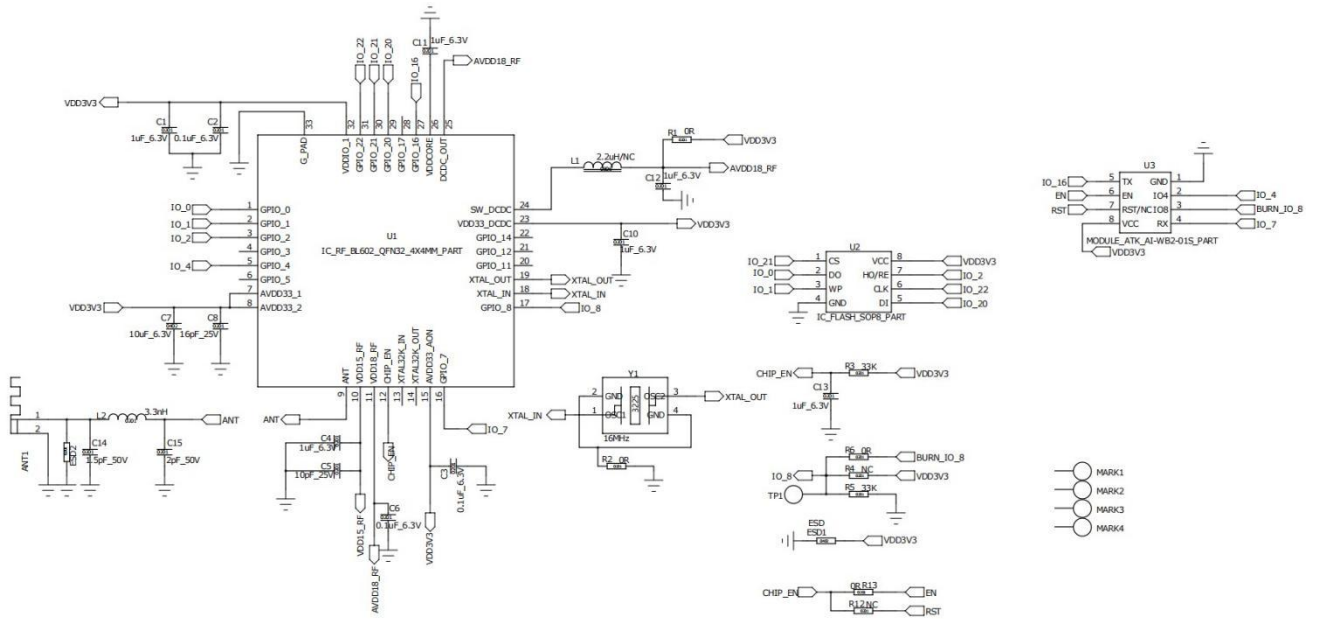

Figure 7 schematic diagram

6. Antenna parameters

6.1. Antenna Test prototype



Figure 8 antenna Test prototype sketch Map

6.2. Antenna S parameters

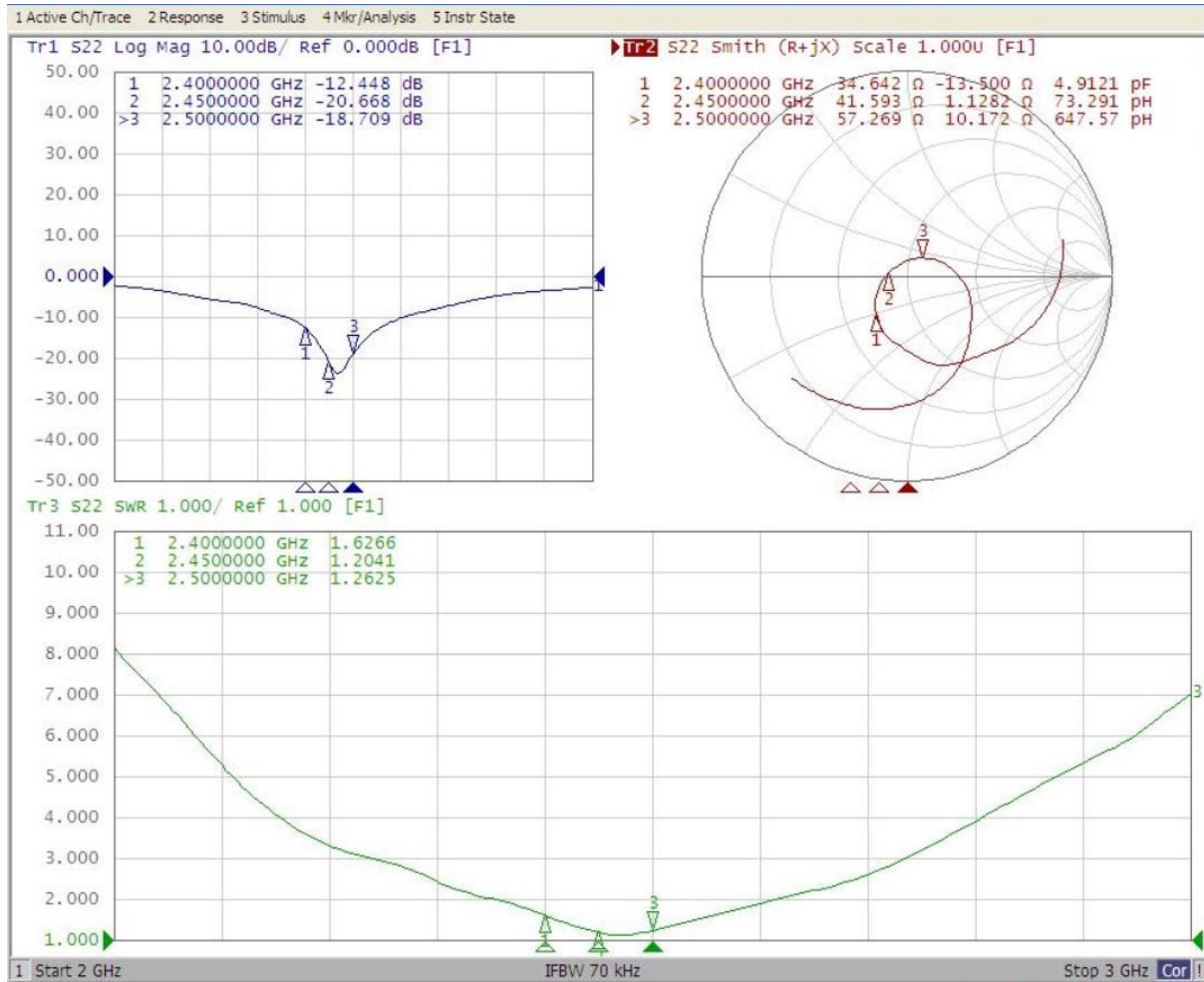

Figure 9 antenna S parameters

6.3. Antenna gain and efficiency

Table 7 antenna gain and efficiency

Frequency ID	1	2	3	4	5	6	7	8	9	10	11
Frequency(MHz)	2400	2410	2420	2430	2440	2450	2460	2470	2480	2490	2500
Gain (dBi)	0.22	0.46	0.84	1.21	1.39	1.61	1.71	1.72	1.67	1.70	1.84
Efficiency (%)	41.43	42.58	44.95	47.63	49.55	53.10	54.63	55.26	55.00	54.57	54.22

6.4. Antenna pattern

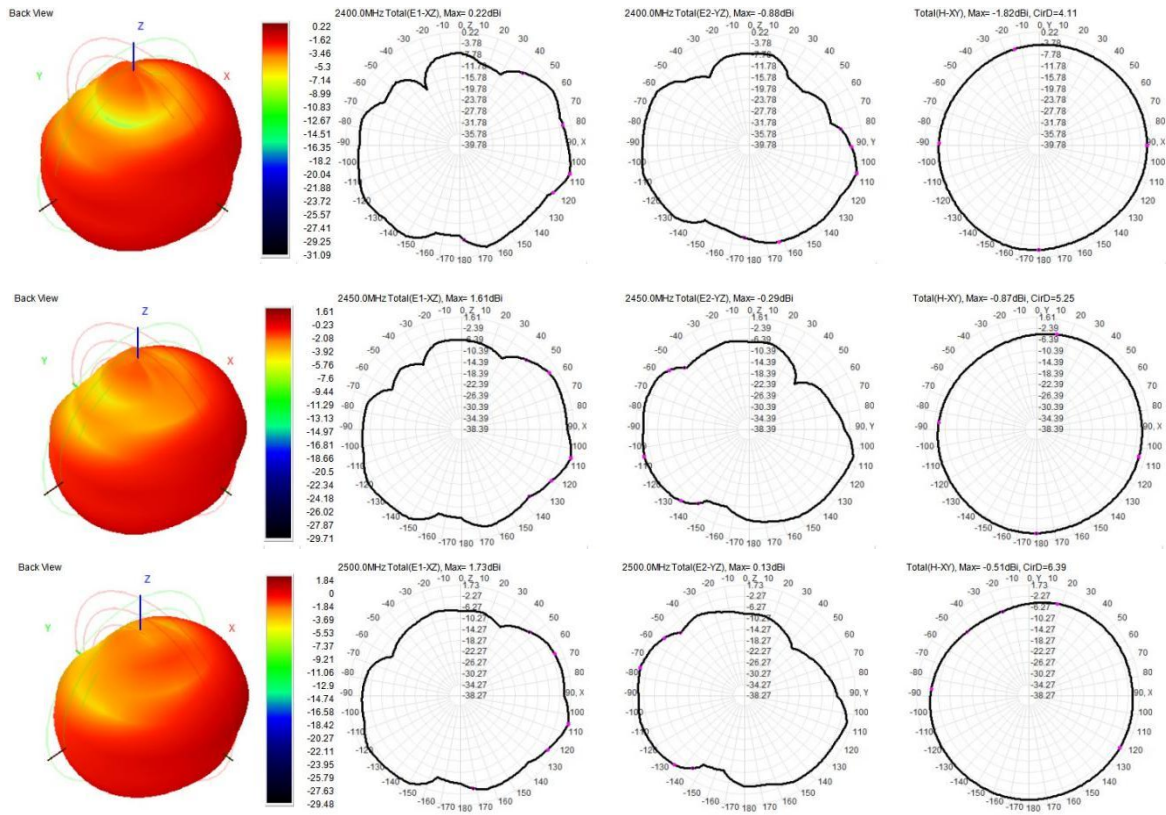

Figure 10 Antenna pattern

6.5. RF OTA parameters

Table 8 RF OTA parameters

Item	Mode	Rate(Mbps)	Channel	Fre.(MHz)	Data(dBm)
TRP	11b	11	1	2412	13.92
			6	2437	13.97
			13	2472	13.49
	11g	54	1	2412	11.7
			6	2437	11.69
			13	2472	11.23
	HT20	MCS7	1	2412	11.61
			6	2437	11.68
			13	2472	11.47
TIS	11b	11	1	2412	-85.02
			6	2437	-83.16
			13	2472	-84.78
	11g	54	1	2412	-70
			6	2437	-70.42
			13	2472	-70.35
	HT20	MCS7	1	2412	-65.52
			6	2437	-65.79
			13	2472	-64.12

7. Design Guidance

7.1. Application Guide circuit

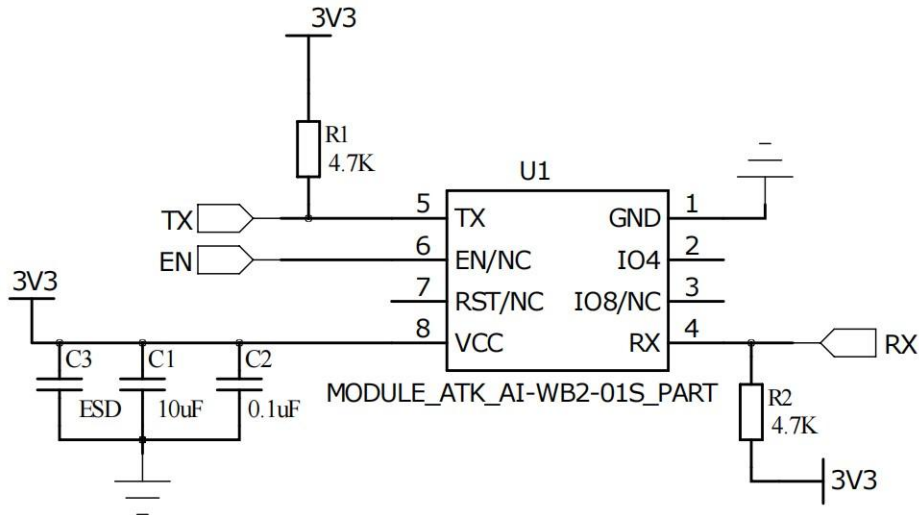

Figure 11 Application circuit diagram

- If the IO port is used as PWM, it is recommended to reserve a 4.7K pull-down resistor around the module. Especially in the application of light control, it can prevent the flashing light phenomenon at the moment of power-on start
- The IO8/NC, RST/NC, which are not available by default. If you need to use it, please contact Ai-Thinker

7.2. Recommend PCB package size

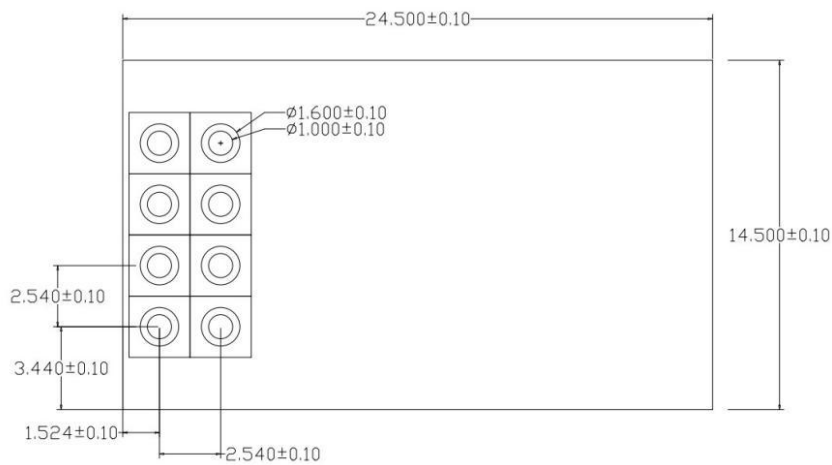

Figure 12 recommended PCB package size (unit: mm)

- Recommended 2.54mm 2*4 row needle base

7.3. Antenna layout requirements

- The installation position on the motherboard is recommended in the following two ways:

Option 1: put the module on the edge of the motherboard, and the antenna area extends out of the edge of the motherboard

Option : put the module on the edge of the motherboard, the edge of the motherboard at the antenna position hollowed out an area

- In order to meet the performance of onboard antenna, it is forbidden to place metal parts around the antenna and keep away from high frequency devices

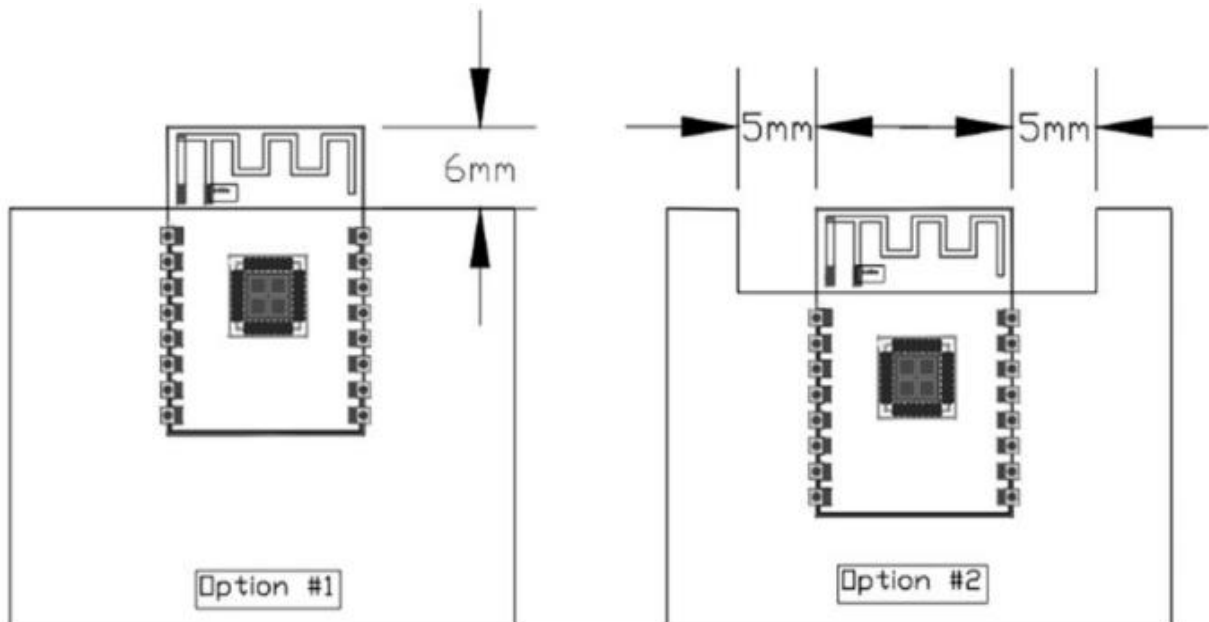

Figure 13 Antenna layout diagram

7.4. Power supply

- Recommended 3.3V voltage, peak current over 500mA.
- We recommend that you use LDO for power supply. If you use DC-DC, we recommend that you control the ripple within 30mV.
- DC-DC power supply circuit is recommended to reserve the position of dynamic response capacitance, which can optimize the output ripple when the load changes greatly.
- It is recommended to add ESD devices to the 3.3V power interface.

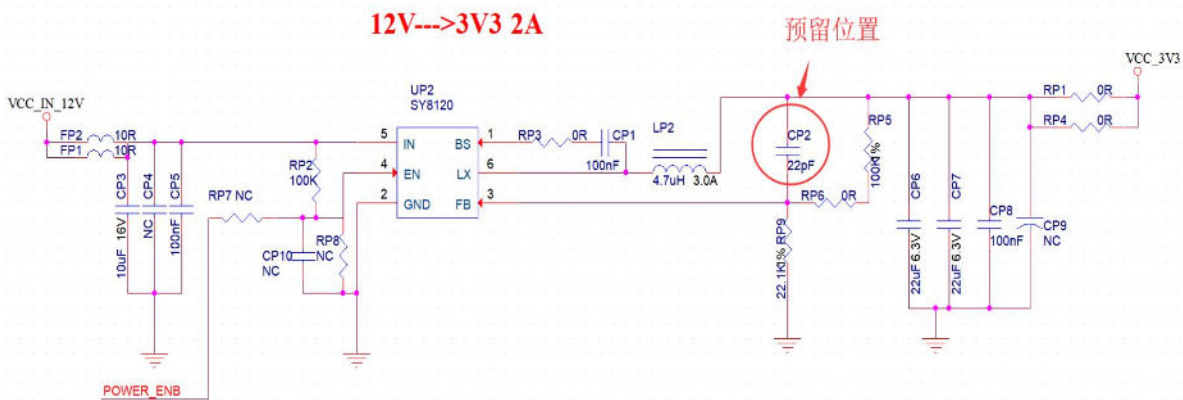

Figure 14 DC-DC step-down circuit diagram

7.5. GPIO

- There are some IO ports on the periphery of the module. If you need to use it, it is recommended to connect a 10-100 ohm resistor in series with the IO port. This inhibits overshoot and makes both sides level more stable. It is helpful for EMI and ESD.
- For special I/O ports to be pulled up and down, refer to the direction for use in the specifications, which may affect the module start-up configuration.
- The I/O port of the module is 3.3V. If the main control does not match the I/O port level of the module, a level conversion circuit needs to be added.
- If the I/O port is directly connected to the peripheral interface, or the terminal such as the row pin, it is recommended to reserve ESD devices near the terminal of the I/O port.

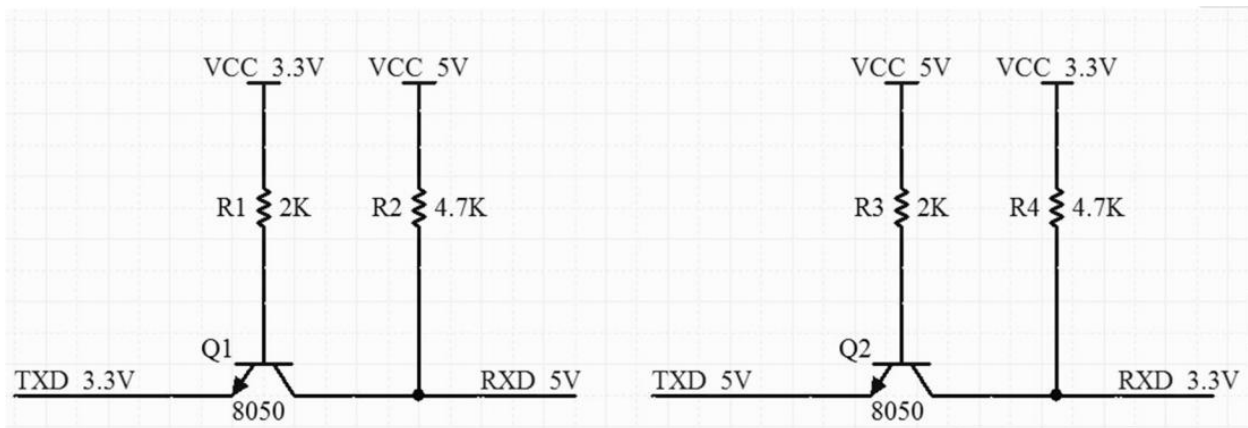

Figure 15 level conversion circuit

8. Storage Conditions

Products sealed in moisture-proof bags shall be stored in a non-condensing atmospheric environment of <math> < 40^{\circ}\text{C}/90\% \text{ RH}</math>.

The humidity sensitivity level MSL of the module is Level 3.

After the vacuum bag is unpacked, it must be used up within 168 hours at $25 \pm 5^{\circ}\text{C}/60\% \text{ RH}</math>, otherwise it can be put on line again after baking.$

9. Reflow welding curve diagram

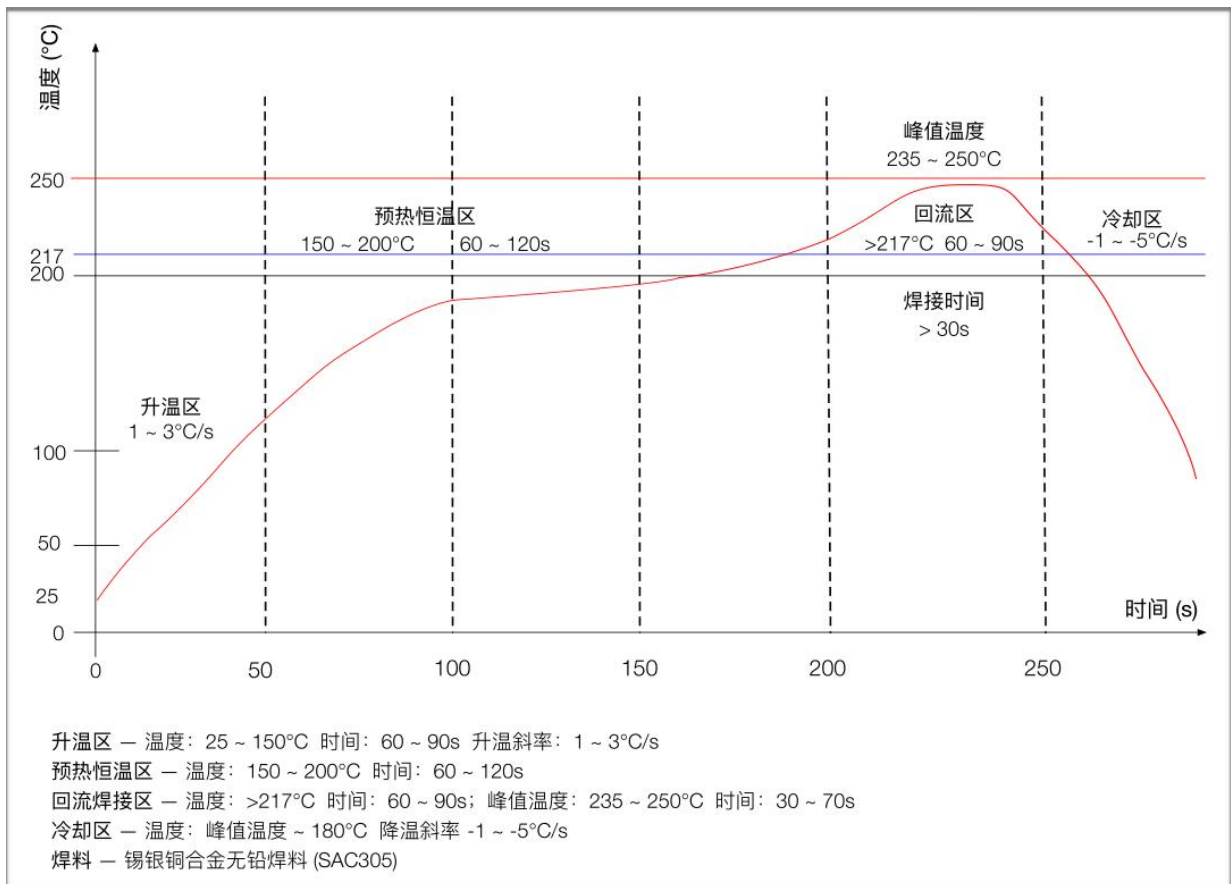

Figure 16 reflow soldering curve

10. Product packaging information

Ai-WB2-01S module was packaged in a tape, 200pcs/reel. As shown in the below image:



Figure 17 Package and packing diagram

11. Contact us

[Ai-Thinker official website](#)

[Office forum](#)

[Develop DOCS](#)

[LinkedIn](#)

[Tmall shop](#)

[Taobao shop](#)

[Alibaba shop](#)

[Technical support email: support@aithinker.com](mailto:support@aithinker.com)

[Domestic business cooperation: sales@aithinker.com](mailto:sales@aithinker.com)

[Overseas business cooperation: overseas@aithinker.com](mailto:overseas@aithinker.com)

Company Address: Room 403,408-410, Block C, Huafeng Smart Innovation Port, Gushu 2nd Road, Xixiang, Baoan District, Shenzhen.

Tel: +86-0755-29162996



WeChat mini program



WeChat official account

Disclaimer and copyright notice

The information in this article, including the URL address for reference, is subject to change without notice.

The document is provided "as is" without any guarantee responsibility, including any guarantee for merchantability, suitability for a specific purpose, or non-infringement, and any guarantee mentioned elsewhere in any proposal, specification or sample. This document does not bear any responsibility, including the responsibility for infringement of any patent rights arising from the use of the information in this document. This document does not grant any license for the use of intellectual property rights in estoppel or other ways, whether express or implied.

The test data obtained in the article are all obtained from Ai-Thinker's laboratory tests, and the actual results may vary slightly.

All brand names, trademarks and registered trademarks mentioned in this article are the property of their respective owners, and it is hereby declared.

The final interpretation right belongs to Shenzhen Ai-Thinker Technology Co., Ltd.

Notice

Due to product version upgrades or other reasons, the contents of this manual may be changed.

Shenzhen Ai-Thinker Technology Co., Ltd. reserves the right to modify the contents of this manual without any notice or prompt.

This manual is only used as a guide. Shenzhen Ai-Thinker Technology Co., Ltd. makes every effort to provide accurate information in this manual. However, Shenzhen Ai-Thinker Technology Co., Ltd. does not guarantee that the contents of the manual are completely free of errors. All statements and information in this manual and the suggestion does not constitute any express or implied guarantee.