



KK 2.1 Multi-Rotor Control Board

User Guide

The next evolution of the rotor revolution is here!! The KK2.1 is packing new found power with updated sensors, memory and header pins.

Designed exclusively for HobbyKing by the grandfather of the KK revolution, Rolf R Bakke, the KK2.1 is the next evolution of the first generation KK flight control boards and has been engineered from the ground-up to bring multi-rotor flight to everyone, not just the experts. The LCD screen and built-in software makes installation and set-up easier than ever.

The original KK gyro system has been updated to the incredibly sensitive 6050 MPU system making this the most stable KK board ever and adds the addition of an auto-level function. At the heart of the KK2.1 is the ATMEL Mega 644PA 8-bit AVR RISC-based microcontroller with 64k of memory.

An additional header has been added for voltage detection, so now there is no need for on-board soldering. A handy piezo buzzer is also included with the board for audio warning when activating and deactivating the board, which can be supplemented with an LED for visual signaling.

A host of multi-rotor craft types are pre-installed, simply select your craft type, check motor layout/propeller direction, calibrate your ESCs and radio and you're ready to go! All of which is done with easy to follow on screen prompts!

If you're new to multi-rotor flight or have been unsure about how to setup a KK board then the KK2.1 was built for you. The 6 Pin USBasp AVR programming interface ensures future software updates will be quick and easy.

Go ahead and get started.

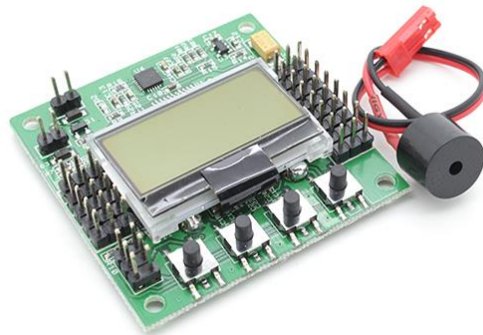

(Version 3 Jan 2014)

© D Bird 2014

Introduction

The HobbyKing KK2.1 Multi-Rotor controller manages the flight of (mostly) multi-rotor Aircraft (Tricopters, Quadcopters, Hexcopters etc). Its purpose is to stabilize the aircraft during flight and to do this, it takes signals from on-board gyroscopes (roll, pitch and yaw) and passes these signals to the Atmega324PA processor, which in-turn processes signals according to the users selected firmware (e.g. Quadcopter) and passes the control signals to the installed Electronic Speed Controllers (ESCs) and the combination of these signals instructs the ESCs to make fine adjustments to the motors rotational speeds which in-turn stabilizes the craft.

The HobbyKing KK2.1 Multi-Rotor control board also uses signals from your radio system via a receiver (Rx) and passes these signals together with stabilisation signals to the Atmega324PA IC via the aileron; elevator; throttle and rudder user demand inputs. Once processed, this information is sent to the ESCs which in turn adjust the rotational speed of each motor to control flight orientation (up, down, backwards, forwards, left, right, yaw).

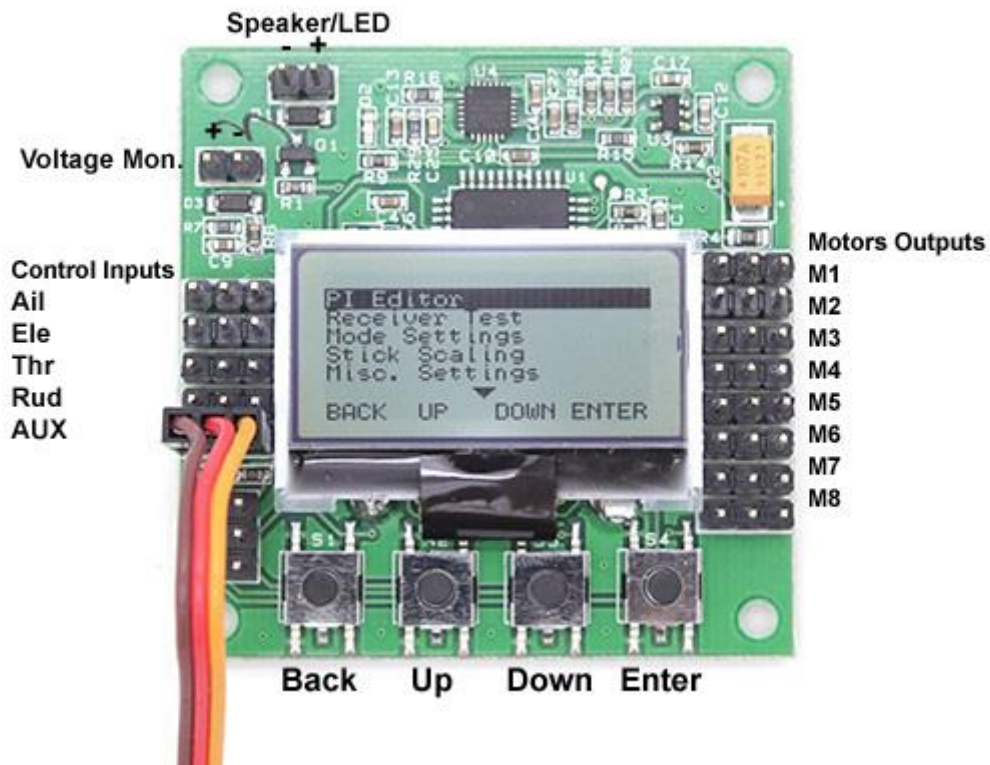

Initial Set-Up



STEP-1 Mount the FC on the frame with the LCD facing front and the buttons facing back. You can use the supplied anti-static foam container as a form of protective case for the Flight Controller on the craft.

STEP-2 Connect the receiver outputs to the corresponding left-hand side of the controller board. The pins are defined as:

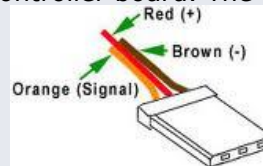

Ensure the negative (black or brown) is orientated so that it is on the pin that is nearest to the edge of the Flight Controller Board, so looking at the board the colour sequence will be Black, Red and Orange. The channels are connected as follows from the front of the board towards the push buttons: -

<u>Receiver Channel</u>		<u>Flight Controller</u>
Aileron	---	Aileron
Elevator	---	Elevator
Throttle	---	Throttle
Rudder	---	Rudder
AUX1	---	AUX

Typical receiver servo connections are:

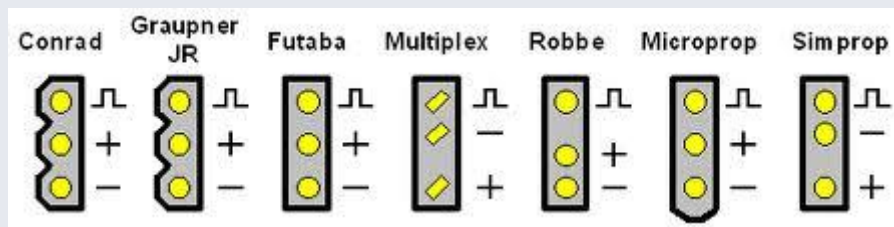

STEP-3 Connect the ESC's to the right side of the Flight Controller Board. M1 is towards the front of the board and M8 is nearest to the push buttons. The negative (black or brown) lead towards the edge of the FC. The negative (black or brown) lead is connected to the edge of the Flight Controller.

DO NOT MOUNT THE PROPELLERS AT THIS STAGE – FOR SAFETY REASONS

The completed Receiver and Motor wiring (for a QUAD Copter) looks like this:

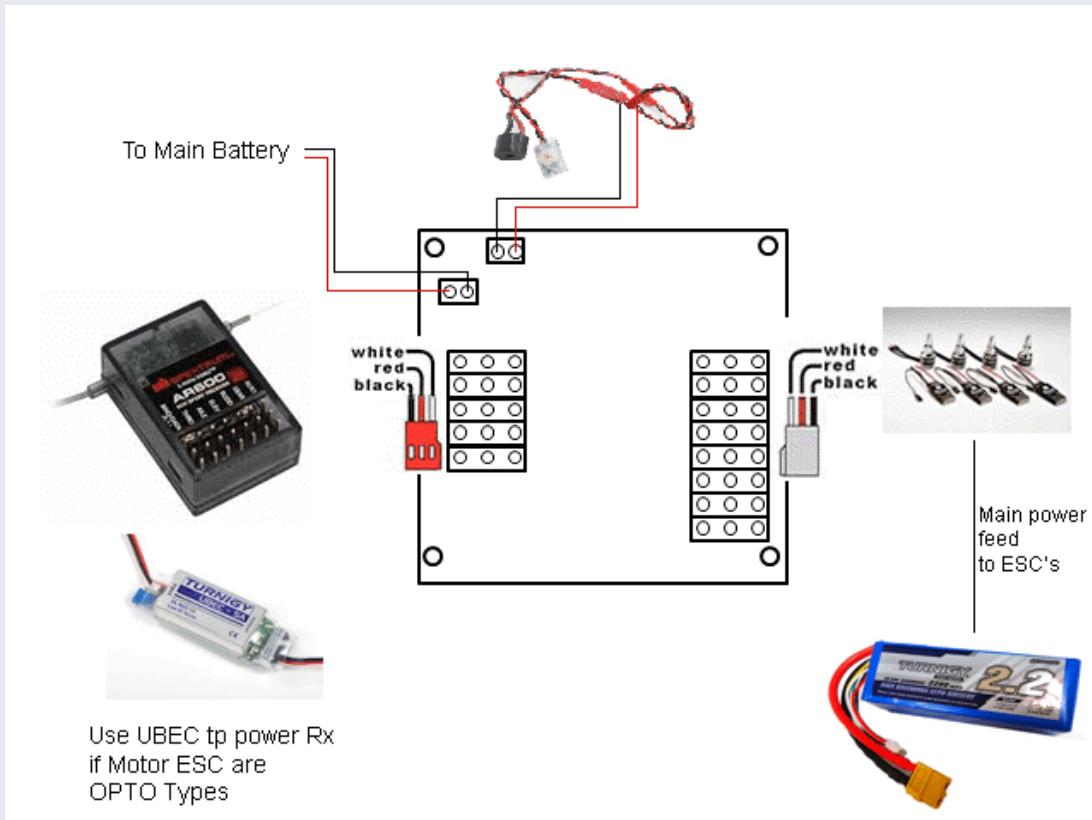

The Flight Controller Board must always have a source of +5v from an ESC, either one of the motors ESC or from a separate unit feeding the Receiver. If each ESC has a BEC (normal unless OPTO types) then it may be necessary to remove the power feed from the other ESC, usually by cutting the power line (RED) Cable on the other ESC.

STEP-4 Set up a new model on your transmitter and use a normal airplane profile and bind the Receiver to the Transmitter.



PI Editor

Receiver Test

Mode Settings

Stick Scaling

Misc. Settings

Self-Level Settings

Camera Stab Settings

Sensor Test

ACC Calibration

CPPM Settings

Mixer Editor

Show Motor Layout

Load Motor Layout

Factory Reset

STEP-5 Turn on the power and press the 'Menu' button, then using the 'Up' and 'Down' buttons highlight 'Receiver Test' sub-menu and press Enter. Now move each channel on your transmitter and check that the displayed direction corresponds with the stick movements on the Flight Controller, if any are reversed, then go to your Transmitter and reverse that channel. Check that the AUX channel is showing "ON" when you activate the AUX Switch on your transmitter, if not, reverse the AUX channel on your transmitter.

Use the trim or sub-trim controls on your transmitter to adjust the channel values shown on the LCD to zero.

PI Editor

Receiver Test

Mode Settings

Stick Scaling

Misc. Settings

Self-Level Settings

Camera Stab Settings

Sensor Test

ACC Calibration

CPPM Settings

Mixer Editor

Show Motor Layout

Load Motor Layout

Factory Reset

STEP-6 Scroll down to and enter the "Load Motor Layout" sub-menu and choose the configuration you want. If the configuration you want is not listed, use the "Mixer Editor" sub-menu to make one. See later for more on that.

STEP-7 Enter the "Show Motor Layout" sub-menu and confirm the following. Is the configuration correct? Are the motors and servos connected the correct output? Correct rotation direction? Does the motor speed up when dropping the arm it is mounted on?

PI Editor

Receiver Test

Mode Settings

Stick Scaling

Misc. Settings

Self-Level Settings

Camera Stab Settings

Sensor Test

ACC Calibration

CPPM Settings

Mixer Editor

Show Motor Layout

Load Motor Layout

Factory Reset

STEP-8 Enter the "Receiver test" and check for nominal values on each channel, move your Transmitter sticks around to ensure they are all working, including AUX1.

PI Editor

Receiver Test

Mode Settings

Stick Scaling

Misc. Settings

Self-Level Settings

Camera Stab Settings

Sensor Test

ACC Calibration

CPPM Settings

Mixer Editor

Show Motor Layout

Load Motor Layout

Factory Reset

STEP-9 Enter the "PI Editor" sub-menu and check PI gain values using this option to adjust the gain settings. The PREV and NEXT buttons to select the parameter to change, then press CHANGE. To adjust both Roll and Pitch at the same time, see the "Mode Settings" sub-menu.

At this stage the propellers can be fitted to test the Flight Control board. Hold the craft (!) and Arm with right rudder and zero throttle for a few seconds, it will beep and the RED LED will turn on. Usually you should not arm it until you have put the Multicopter on the ground and stepped 5 meters away. After landing, place it in SAFE Mode by holding the rudder to left with zero throttle, it beeps and the RED LED will turn off, always do this before you approach the Multicopter.

If the craft wants to tip over right away, check the connections and your custom made mixer table if you have one. If it shakes and climbs after it's airborne, adjust the Roll and Pitch Pgain down or if it easily tips over after its airborne, adjust up. If it drifts away, use the trims to

keep the drift down. It will normally drift with the wind. If you need excessive trim, check if the arms and motors have the correct angles and that the motors are good. Increase the Roll and Pitch I gain (note the difference from P gain) until it flies straight forward without pitching up or down. Turn on the Self-levelling by holding right aileron while arming or disarming it. Turn it off by holding left aileron. Alternatively you can assign this to the AUX channel. See below so Sub-menu descriptions.

PI Editor

Receiver Test

Mode Settings

Stick Scaling

Misc. Settings

Self-Level Settings

Camera Stab Settings

Sensor Test

ACC Calibration

CPPM Settings

Mixer Editor

Show Motor Layout

Load Motor Layout

Factory Reset

STEP-10 Enter the "Mode Settings" and check and adjust:

"Self-Level": Determines how the self-levelling function will be controlled, either by STICK or an AUX Channel.

"STICK MODE": Self-levelling is turned on by holding the aileron to the right when arming or disarming. Turn it off with left aileron.

"AUX": Self-levelling is turned on/off by the AUX Channel.

"Auto Disarm": If set to YES then Flight Control board will automatically disarm itself after 10-mins of inactivity.

"CPPM Enabled": Determine if the Flight Control Board is to use CPPM data input.

PI Editor

Receiver Test

Mode Settings

Stick Scaling

Misc. Settings

Self-Level Settings

Camera Stab Settings

Sensor Test

ACC Calibration

CPPM Settings

Mixer Editor

Show Motor Layout

Load Motor Layout

Factory Reset

STEP-11 Enter the "Stick Scaling" option, where you can adjust the response from the stick to your liking. Higher number gives higher response and lower numbers the converse. This is similar to the endpoint or volume adjustment on your transmitter, where you can adjust your transmitter to adjust the stick response and use the stick scaling if you want more or less response from stick inputs.

"Misc. Settings":

"Minimum Throttle": Adjust the setting so that the motors just keep running when the Transmitter throttle stick is at a minimum.

"Height Dampening": This option uses the Z accelerometer to dampen vertical movements caused by wind or when tilting the craft. A recommended setting is 30.

"Height D. Limit": Adjust to limit control for Height Dampening to prevent over control, this limits how much power is available for dampening. A recommended setting is 10 (10%).

"Alarm 1/10 volts": Adjusts the battery alarm voltage set-point. When set to 0 (zero) the alarm is disabled. Adjust this value to suit the battery in use and monitored by the Flight Control Board sensor input. For a standard 3-cell LiPo battery of 11.1volts use a value of 3.60 volts per cell to denote an empty battery and then set this value (in 1/10's) to $(3.6 \times 3 \times 10) = 108$ and when the supply voltage drops to 10.8volts the alarm will sound. Note, if you set this value above zero and no battery is attached / monitored then the alarm will sound. As the voltage being monitored nears the set point the time between beeps will shorten, so a long time between pulses when the alarm voltage is getting close to very short time intervals when the voltage is at the alarm set point.

"Servo Filter": This setting is a Low-Pass Filter, that enables channel jitter to be ignored, a good setting to start off with is 50 (mS). If you experience channel jitter then increase this value, if none then set to 0 (zero).

PI Editor
Receiver Test
Mode Settings
Stick Scaling
Misc. Settings
Self-Level Settings
Camera Stab Settings
Sensor Test
ACC Calibration
CPPM Settings
Mixer Editor
Show Motor Layout
Load Motor Layout
Factory Reset

"Sensor Test":

Displays the output from the sensors. See if all shows "OK". Move the FC around and see that the numbers change.

"ACC Calibration":

Follow the instructions on the LCD to calibrate the Acceleration Sensors, which is only necessary to do once at initial setup.

PI Editor
Receiver Test
Mode Settings
Stick Scaling
Misc. Settings
Self-Level Settings
Camera Stab Settings
Sensor Test
ACC Calibration
CPPM Settings
Mixer Editor
Show Motor Layout
Load Motor Layout
Factory Reset

"CPPM Settings":

This menu allows different Transmitter manufacturers standards for CPPM channels to be re-assigned, thus:

Roll (Ail):	1	to	2 (an example)
Pitch (Ele):	2	to	1 (an example)
Throttle:	3	to	4 (an example)
Yaw(Rud):	4	to	5 (an example)
AUX:	5	to	3 (an example)

This enables the Flight Control board to match any supplier's standard.

PI Editor

Receiver Test

Mode Settings

Stick Scaling

Misc. Settings

Self-Level Settings

Camera Stab Settings

Sensor Test

ACC Calibration

CPPM Settings

Mixer Editor

Show Motor Layout

Load Motor Layout

Factory Reset

"Mixer Editor":

"Channel": Select the channel to be adjusted.

"Throttle": Amount of throttle command. Usually 100% if the output channel is connected to an ESC.

"Aileron": Amount of aileron/roll command. Use positive value for motors on the right side of the roll axis and negative for the left side of the roll axis. The value is given by the motor's distance from the roll axis. Increased values denote a further distance.

"Elevator": Amount of elevator/pitch command. Use a positive value for motors on the front side of the pitch axis and negative value for the back side of the pitch axis. The value is given by the motor's distance from the pitch axis. More is further away.

"Rudder": The amount of rudder/yaw command. Usually 100%. Use a positive value for a CW spinning propeller and negative for a CCW spinning propeller.

"Offset" Item: Applies a constant offset to the channel. Keep this zero when it is an ESC channel and around 50% when connected to a servo or on the AUX channel. You can fine tune the channels position by adjusting this value.

"Type:" Item: Set it to the type (servo or ESC) connected to the channel. For ESC: Output PWM rate is always high. Outputs zero when disarmed or throttle is at idle. Applies the "Minimum Throttle" item from the "Misc. Settings" sub-menu when armed and throttle is above zero. For the Servo setting: Output PWM rate can be high or low. Outputs the offset value when disarmed or throttle is at idle.

"Rate": High rate (400Hz) for ESC or digital servos, or low rate (80Hz) for analogue servos.

Tuning Guide

1: Make sure the KK2 reads the transmitter stick neutrals. Go to the "Receiver Test" menu and use the trims to get the values to zero.

2: Go to the "PI Editor" menu and set P to 50 and I to zero for both the Roll and Pitch Axis. It is only necessary to edit the roll axis, pitch axis will be automatically changed to the same values as the roll axis. Leave the P-limit and I-limit alone, it is not necessary to change them.

3: Hover the aircraft and compare the response and adjust accordingly if required.

If you are a new flier and the craft is not yet flying around, just leave the I-gain at zero or the default value. Also the Yaw PI-gains can be left at default, but remember to zero them if you use the 'string' (the craft suspended from a piece of string along one of its axis) tuning method.

Recommended / Default PI editor settings for first flight:

Roll/Pitch Axis:

Pgain = 50

Plimit = 100

Igain = 25

Ilimit = 20

Yaw Axis:

Pgain = 50

Plimit = 20

Igain = 25

Ilimit = 10

Default gains are set to 50/50/50 (roll/pitch/yaw) P-term, and 25, 25, 50 I-term.

Limits are used to limit the maximum value of the control that can be used to make corrections and a value of 100 means 100%. The "I limit" value is also known as "anti wind-up" in PID theory and use of Limits is most important on the yaw axis to prevent a yaw correction from saturating the motors (giving full or no throttle), then causing no control to the roll/pitch axis. The default values permit 30% ("P Limit" 20 + "I limit" 10) of the motor power to be used to make a yaw correction, with 70% available for the roll/pitch axis. The "Yaw P Limit" can be increased for faster Yaw response, but note Yaw response is limited by the craft dynamics itself. You can increase "Roll/Pitch/Yaw I Limit" for increased heading-hold "memory", that is how far it can deviate and still return to the original attitude. However, if set too high, problems occur as the controller tries to correct with opposite control input and then when the conditions disappear, the craft will try to return to an unknown attitude. It is recommended to leave the limit values as default. Default values have no impact on The PI tuning process. Also leave the self-level "I gain" and "I limit" at zero.

Tuning P and I settings

P-gain too low:

- Craft is hard to control
- When flying it is easy to over-correct a command and the craft is jittery
- Craft lacks overall stability
- Control inputs feels slow and imprecise when the craft responds

P-gain too high:

- Craft suffers from side to side oscillation
- Craft easily gains or loses height
- It is hard to maintain any given height

P-gain correct:

- Craft is easy to control
- Craft takes off easily and smoothly straight into a stable hover
- Craft is easy to fly and feels stable

I-gain too high:

- Similar flight characteristics to P-gain that is too high
- Craft oscillates with a low frequency, shakes
- Craft flies a 'toilet-bowel' circuit

Aerobatic flight PI Settings:

Increase the P setting slightly from its stable flight value

Decrease the I setting from its stable flight value

Gentle smooth flight:

Decrease the P setting slightly from its stable flight value

Increase the I setting a slightly from its stable flight value

Proportional Gain coefficient –is needed for relatively stable flight and is an essential parameter. This coefficient determines the mix between on-board controls from the gyros and user stick inputs. As the coefficient is increased the craft will be more sensitive and reactive to angular changes. If too low, the craft will be sluggish and difficult to keep steady and if too high, may oscillate with a high frequency.

Integral Gain coefficient – is needed to increase the precision of an angular position. For example when the craft is disturbed by wind and its angular position changes by say 20 degrees, it in theory remembers how much the angle changed and will attempt to return by 20 degrees. In practice if the craft goes forward and then command a stop, it will continue for some time to counteract the action. Without this term, the opposition does not last as long. This term is especially useful with irregular wind, and ground effect (turbulence from motors). If the However, when the 'I' value gets too high your craft will begin to have slow reactions and will decrease the effect of the Proportional gain as consequence, it will also start to oscillate as if it has the P gain set to high, but with a lower frequency.

Gimbal Connection Guide

PI Editor
Receiver Test
Mode Settings
Stick Scaling
Misc. Settings
Self-Level Settings
Camera Stab Settings
Sensor Test
ACC Calibration
CPPM Settings
Mixer Editor
Show Motor Layout
Load Motor Layout
Factory Reset

Enable the Camera Control by turning it on by going to "Cam Stab Settings" screen and set the gains to a non-zero value. Start with 500. A negative value reverses servo direction. Adjust value until camera is steady.

1. The Gimbal Roll servo is connected to Motor-7 output.
2. The Gimbal Pitch servo is connected to Motor-8 output.

Connection diagram:

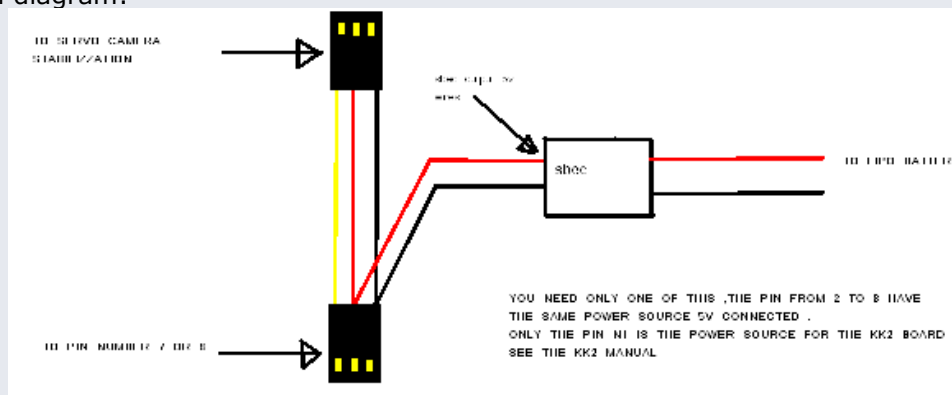

3. Use the offset values to trim servo position, but keep the values close to 50% by adjusting servo linkage first.
4. The camera stabilisation starts as soon as you move the Throttle any stick
5. If you put the Throttle at Idle/Minimum the camera stabilisation will be switched-OFF. NOTE: If you are using an "OPTO" ESC you may need an external 5v power source from an SBEC.

Accessing the Self-Levelling Mode

1. You can access the self-levelling mode either from the settings of STICK or AUX channel.
2. When set to AUX Mode you must connect a spare channel usually CH5 or Ch6 and changing the Transmitter switch position will enable/disable Self-Levelling mode.
3. When set to STICK Mode to go into Self-Levelling Mode, you must set the Throttle to Minimum and set maximum Left Rudder whilst at the same time, setting maximum Left Aileron to disable SL or maximum Right Aileron to enable SL.

Flight Controller Sounds

1. One Beep (short beep, 2 sec delay) is emitted when the board is armed and the throttle is closed, this is for safety reasons so you know it's armed.
2. One Long Beep is emitted when the board is either Armed or Disarmed.

Status Screen

1. Displays the message "SAFE" and the KK2 will not arm unless it says "OK"

General Points

1. Error messages can only be reset by cycling the power, except for the "sensors not calibrated" message, which is reset after a successful sensor calibration.
2. Error messages include lost RX connection.
3. The KK2.1 has an auto-disarm function and will disarm itself after 20 sec if throttle is at idle. For extra safety. Can be turned on/off in "Mode Settings" menu.

Lost Model Alarm

1. The KK2.1 has a lost aircraft alarm and starts to beep (1 sec on and 4 sec off) after 30min of no activity (arm/disarm).

Model Types Supported

Dualcopter
Tricopter
Y6
Quadcopter +
Quadcopter X
Hexcopter +
Hexcopter X
Octocopter +
Octocopter X
X8 +
X8 X
H8
H6
V8
V6
Aero 1S Aileron
Aero 2S Aileron
Flying Wing
Singlecopter 2M 2S
Singlecopter 1M 4S